

Technical Manual

Multi Function Modules for Integration into Dental equipment



Micromotor Module : NLX

Indication

Treatment

NLX nano motor	- Tooth cutting - PMTC (Professional Mechanical Tooth Cleaning)
NLX plus motor	- Tooth cutting - PMTC (Professional Mechanical Tooth Cleaning) - Endodontic treatment

- The product may be damaged if the setting is not correct.
Some switches and potentiometers may not be necessary for NLX nano motor.
Check wiring diagram case and NLX BF connections, and select the proper connection.
- When DIP switch setting is wrong, the product will not work properly and may be damaged.

Index

NLX BF Individual Components	1
Selection Chart	5
NLX BF Connections - One Motor External I/F Control	6
Wiring Diagram Case1 - One Motor External I/F Control	7
NLX BF Connections - One Motor Multi Pad Control	8
Wiring Diagram Case2 - One Motor Multi Pad Control	9
NLX BF Connections - One Motor Remote Control	10
Wiring Diagram Case3 - One Motor Remote Control	11
NLX BF Connections - Two Motors External I/F Control	12
Wiring Diagram Case4 - Two Motors External I/F Control	13
NLX BF Connections - Two Motors Multi Pad Control	14
Wiring Diagram Case5 - Two Motors Multi Pad Control	15
NLX BF Connections - Two Motors Remote Control	16
Wiring Diagram Case6 - Two Motors Remote Control	17
Correlation of the Motor Speed and the Air Foot Control Pressure	18
Correlation of the Motor Speed and Voltage of the External I/F Speed Potentiometer	18
Wiring Diagram MP02/MPS02 (Multi Pad AX)	19

NLX BF Individual Components

NLX Control PCB

Control PCB (PCB with case)

Dimensions with case: W115 x D68.5 x H40 (mm)



MODEL
NLX BF D1C0

ORDER CODE
U1020011

Control PCB (PCB only)

Dimensions: W102 x D62 x H26.6 (mm)



MODEL
NLX BF D1C0B

ORDER CODE
U1020010

AC-DC Adapter PCB

AC-DC Adapter PCB (PCB with case)

Dimensions with case: W60.2 x D81.4 x H45.2 (mm)



MODEL
NLS-A ADP

ORDER CODE
U1020050

AC-DC Adapter PCB (PCB only)

Dimensions: W50 x D50 x H36.6 (mm)



MODEL
NLS-A ADPB

ORDER CODE
U1020051

Selector PCB

Selector PCB (PCB with case)

Dimensions: W62 x D50 x H21.6 (mm)



MODEL
NLS-A SEL

ORDER CODE
U1020055

Selector PCB (PCB only)

Dimensions with case: W68.5 x D56.5 x H38.5 (mm)



MODEL
NLS-A SELB

ORDER CODE
U1020056

Micromotors and cords

Micromotor	
	MODEL NLX nano
	ORDER CODE E1044051

Micromotor	
	MODEL NLX plus
	ORDER CODE E1040051

Motor Cord (For NLX nano Micromotor)	
	MODEL nano CDB (Only for NLX nano, Short rear cover Type)
	ORDER CODE E1044066
	MODEL nano LCDB (Only for NLX nano, Long rear cover Type)
	ORDER CODE E1044067

Motor Cord (For NLX plus Micromotor)	
	MODEL plus CD (Only for NLX plus, Short rear cover Type)
	ORDER CODE E1040066
	MODEL plus LCD (Only for NLX plus, Long rear cover Type)
	ORDER CODE E1040067

Multi Pad

The Multi Pad can control the NLX BF and also Varios 170.

Multi Pad (Manual Selection Type)	
<p>Manual Selection Type :</p> <p>Selects instruments by pressing the Esc key.</p> <p>This is add-on type to be installed on an existing chair unit.</p>	MODEL MP01
	ORDER CODE U1018001
	MODEL MPS01 (MP01 with Angle Plate)
	ORDER CODE Y1001845



Multi Pad AX (Auto Selection Type)	
<p>Auto Selection Type :</p> <p>Selects instruments automatically.</p> <p>This is suitable for designing Multi-Pad-embedded chair units.</p> <p>Instrument holder switch and Foot Control need to be designed for this type of Multi Pad.</p>	MODEL MP02
	ORDER CODE U1018002
	MODEL MPS02 (MP02 with Angle Plate)
	ORDER CODE Y1001846



Lead Connectors

Motor	
	MODEL LEAD CONNECTOR
	ORDER CODE U522057

RS-232	
	MODEL LEAD CONNECTOR
	ORDER CODE 20000902

Lamp	
	MODEL LEAD CONNECTOR
	ORDER CODE U522058

CAN	
	MODEL LEAD CONNECTOR
	ORDER CODE 20000906

A/B select	
	MODEL LEAD CONNECTOR
	ORDER CODE 20000907

External I/F	
	MODEL LEAD CONNECTOR
	ORDER CODE 20000903

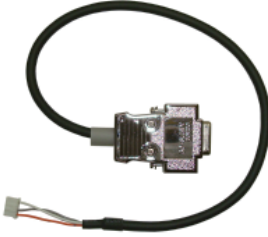
RS-232C for PC		
Connect D-Sub 9pin connector to serial port.		MODEL LEAD CONNECTOR
		ORDER CODE 20001442

CAN for PC		
Connect D-Sub 9pin connector to CANUSB dongle.		MODEL LEAD CONNECTOR
		ORDER CODE 20001441

Options

Varios 170 Optic Complete Set		
With a harness connectable to the Multi Pad.		MODEL VA170LUXS5
		ORDER CODE Y1002114

Varios 170 Non-Optic Complete Set		
With a harness connectable to the Multi Pad.		MODEL VA170S5
		ORDER CODE Y1002115

Magnetic Solenoid Valve		
	MODEL SOLENOID VALVE (OPTION)	
	ORDER CODE U387014	

Selection Chart

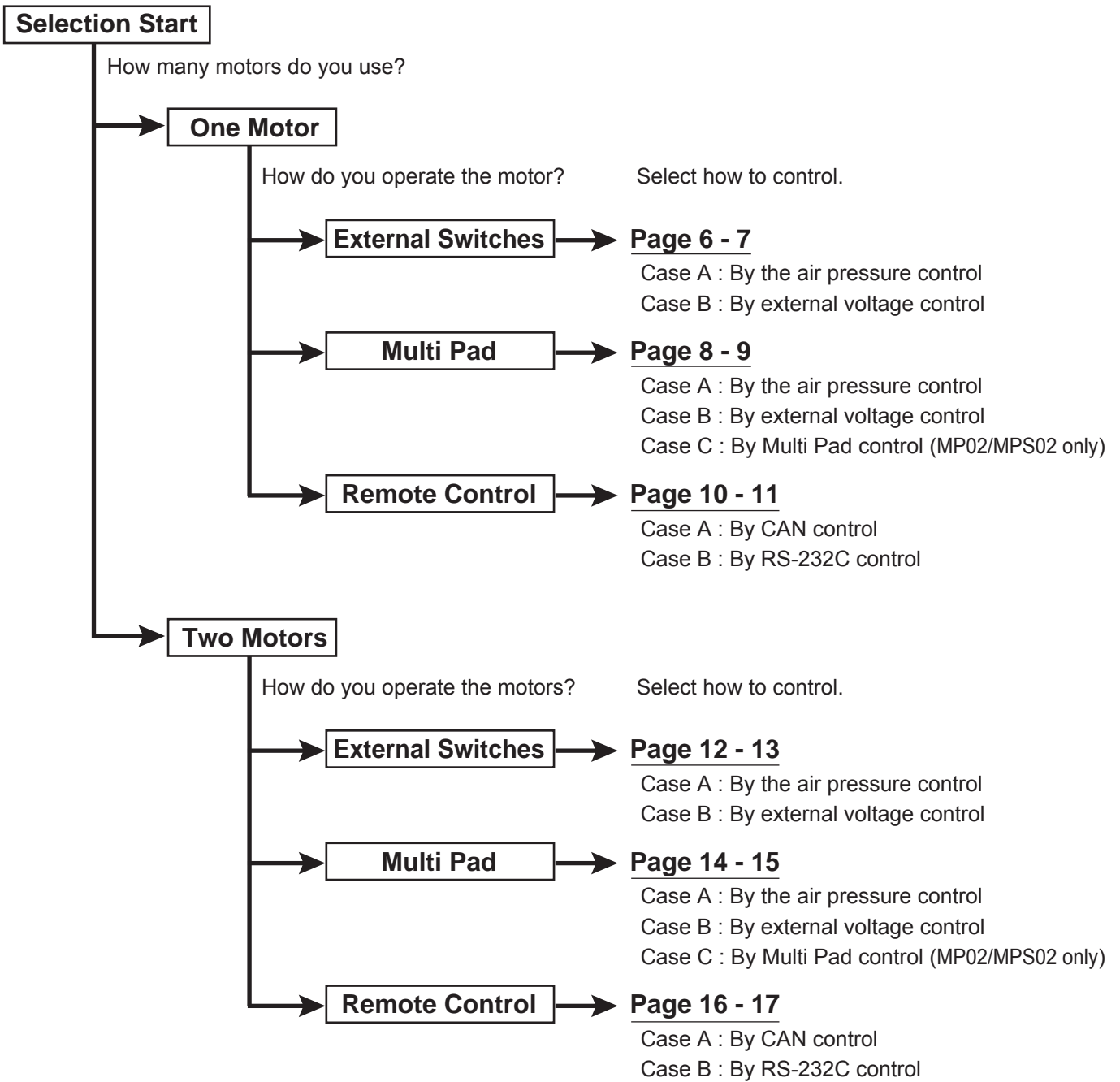

NLX BF Connections - One Motor External I/F Control

Select how to control the speed

- Case A: By the air pressure control.
- Case B: By external voltage control.

<Case A> Speed controlled by air Foot Control

- Connect the air tube from drive air to IC301 (Air pressure sensor)
- DIP switch: Bit3 ON
- Drive air pressure: Max 0.29MPa
- For correlation of the motor speed and the air pressure, refer to 18 page.

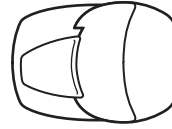

- Connect switch or transistor of open collector output with the switch.
- Connect potentiometer or DAC output from microcomputer with the potentiometer.

ON: Rotates by taking the motor from the holder
 OFF: No rotation
 DIP switch: Bit4 OFF

Motor ON/OFF Switch

Motor FWD/REV Switch

Not necessary for NLX nano motor.

- Motor High mode/Endo Mode Switch
- Motor Auto Reverse ON/OFF Switch
- Motor Auto Forward/Auto Reverse Switch

<Case B> Speed controlled by external voltage

- Connect wiring to the potentiometer.
- DIP switch: Bit3 OFF
- For correlation of the motor speed and voltage of the potentiometer, refer to 18 page.

Not necessary if Bit2 of DIP switch is on.

Speed Potentiometer

Speed Limit Potentiometer

Not necessary for NLX nano motor.

Torque Potentiometer

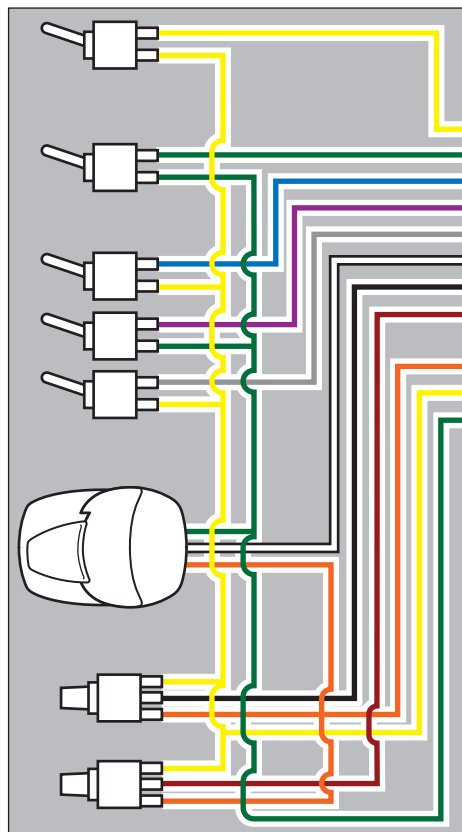

NLX BF PCB

IC301 (Air Pressure Sensor)

CN300 (External I/F)

1	MOT_ON	Yellow
2	MOT_ROT	Green
3	MOT_H/L	Blue
4	AUTO_R	Purple
5	AUTO_RF	Gray
6	SPEED_VR	White
7	LIMIT_VR	Black
8	TRQ_VR	Brown
9	MOT_MUX	Red
10	+5V	Orange
11	GND	Yellow
12	GND	Green

CN301 (CAN Bus)

1	CAN_L	Red
2	CAN_H	Orange
3	Unused	-

CN302 (RS-232C)

1	GND	Green
2	Unused	-
3	RX_DATA	Orange
4	TX_DATA	Red

CN305 (Lamp OUT)

1	LAMP_V	Orange
2	GND	Yellow

CN306 (Motor Select OUT)

1	SEL_MA/B	Blue
2	+12V	Purple

CN104 (Motor OUT)

1	MOT_W	Brown
2	MOT_V	Black
3	MOT_U	Red

CN105 (DC IN)

1	GND	Black
2	DC+34V	Red



AC-DC Adapter PCB

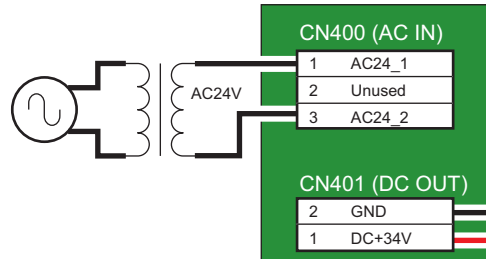

AC-DC Adapter is not necessary if DC power is supplied.



Wiring Diagram Case1 - One Motor External I/F Control

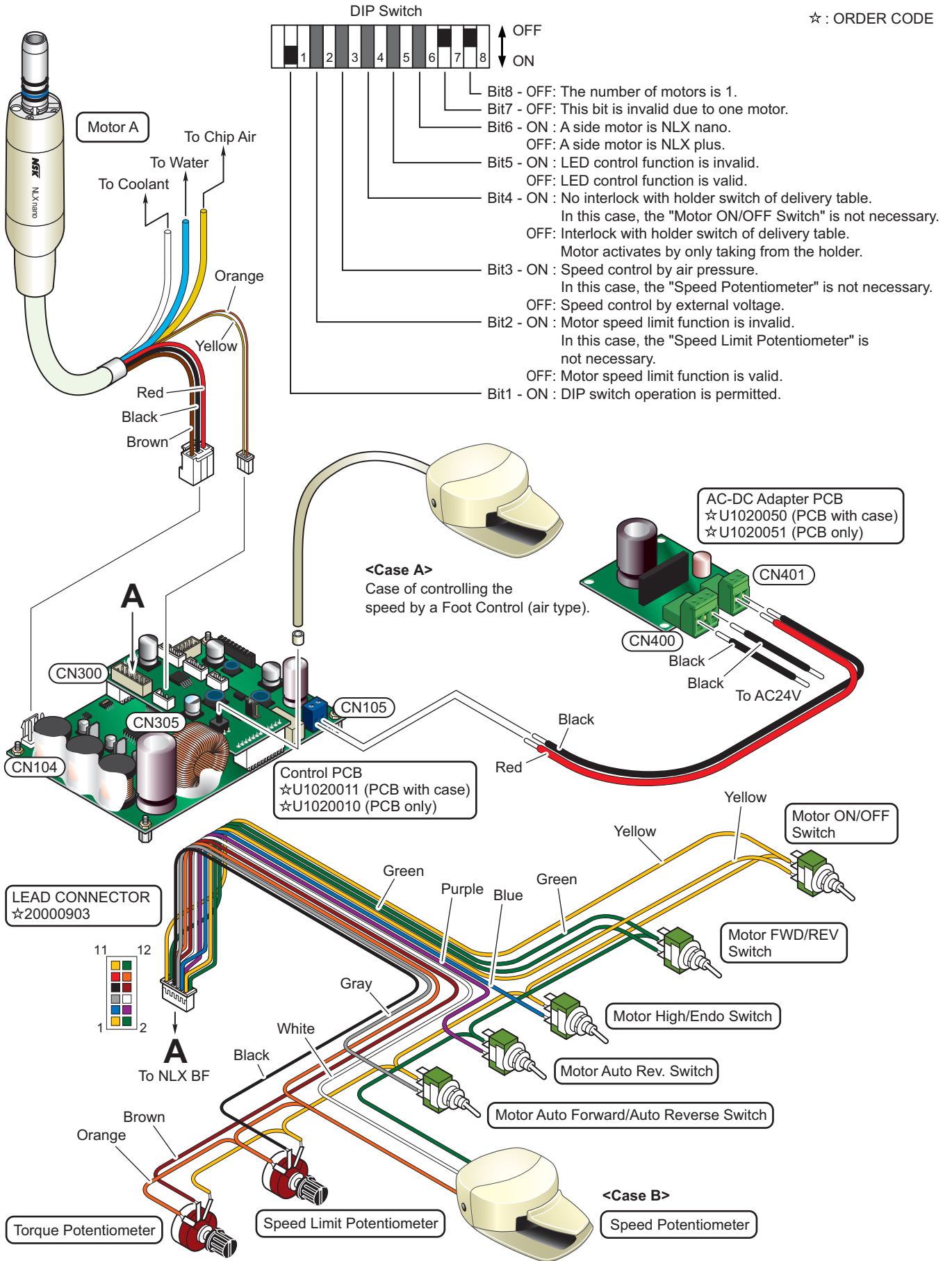

NLX BF Connections - One Motor Multi Pad Control

Select how to control the speed

- Case A: By the air pressure control.
- Case B: By external voltage control.
- Case C: By Multi Pad control (MP02/MPS02 only). Refer to 19 Page.

<Case A> Speed controlled by air Foot Control

- Connect the air tube from drive air to IC301 (Air pressure sensor)
- DIP switch: Bit3 ON
- Drive air pressure: Max 0.29MPa
- For correlation of the motor speed and the air pressure, refer to 18 page.

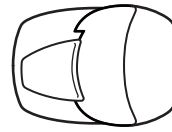

- Connect switch or transistor of open collector output with the switch.
- Connect potentiometer or DAC output from microcomputer with the potentiometer.

ON: Rotates by taking the motor from the holder
 OFF: No rotation
 DIP switch: Bit4 OFF

Motor ON/OFF Switch

Speed Potentiometer

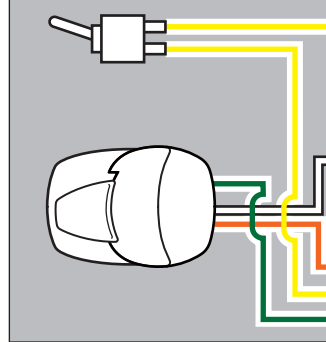

<Case B> Speed controlled by external voltage

- Connect wiring to the potentiometer.
- DIP switch: Bit3 OFF
- For correlation of the motor speed and voltage of the potentiometer, refer to 18 page.

NLX BF PCB

IC301 (Air Pressure Sensor)

CN300 (External I/F)

1	MOT_ON	Yellow
2	MOT_ROT	Green
3	MOT_H/L	Blue
4	AUTO_R	Purple
5	AUTO_RF	Gray
6	SPEED_VR	White
7	LIMIT_VR	Black
8	TRQ_VR	Brown
9	MOT_MUX	Red
10	+5V	Orange
11	GND	Yellow
12	GND	Green

Ultrasonic Scaler (VA170)

OPTION

OPTION

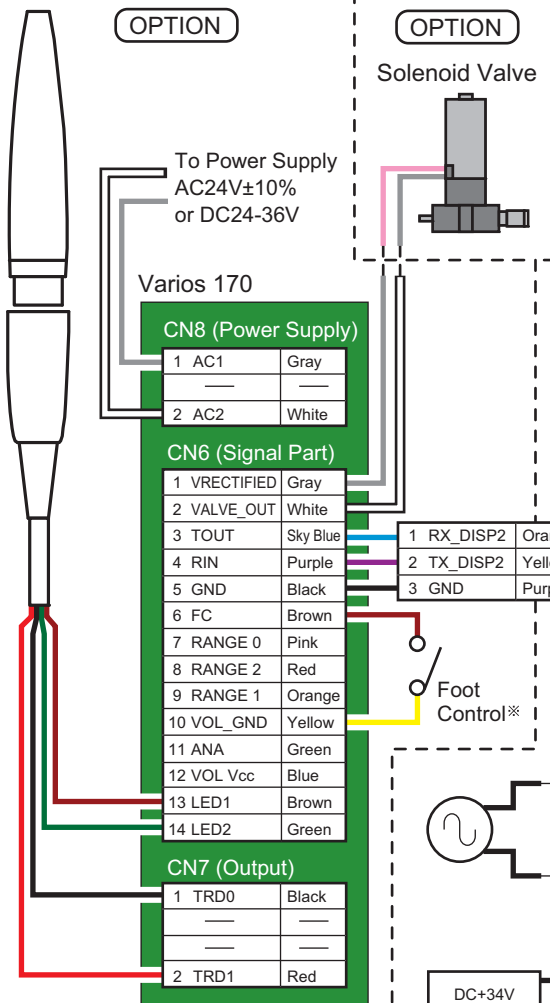

Multi Pad

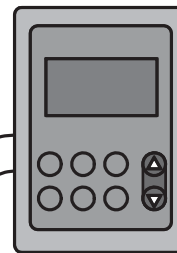

CN301 (CAN Bus)

1	CAN_L	Red
2	CAN_H	Orange
3	Unused	-

CN302 (RS-232C)

1	GND	Blue
2	+12V	Green
3	RX_DATA	Red
4	TX_DATA	Brown

CN305 (Lamp OUT)

1	LAMP_V	Orange
2	GND	Yellow

CN306 (Motor Select OUT)

1	SEL_MA/B	Blue
2	+12V	Purple

CN104 (Motor OUT)

1	MOT_W	Brown
2	MOT_V	Black
3	MOT_U	Red

CN105 (DC IN)

1	GND	Black
2	DC+34V	Red

Motor



AC-DC Adapter PCB

CN400 (AC IN)

1	AC24_1	
2	Unused	
3	AC24_2	

CN401 (DC OUT)

2	GND	
1	DC+34V	

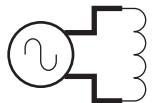

DC+34V

AC-DC Adapter is not necessary if DC power is supplied.

※ Not necessary when using Multi Pad control (MP02/MPS02).

Wiring Diagram Case2 - One Motor Multi Pad Control

☆: ORDER CODE

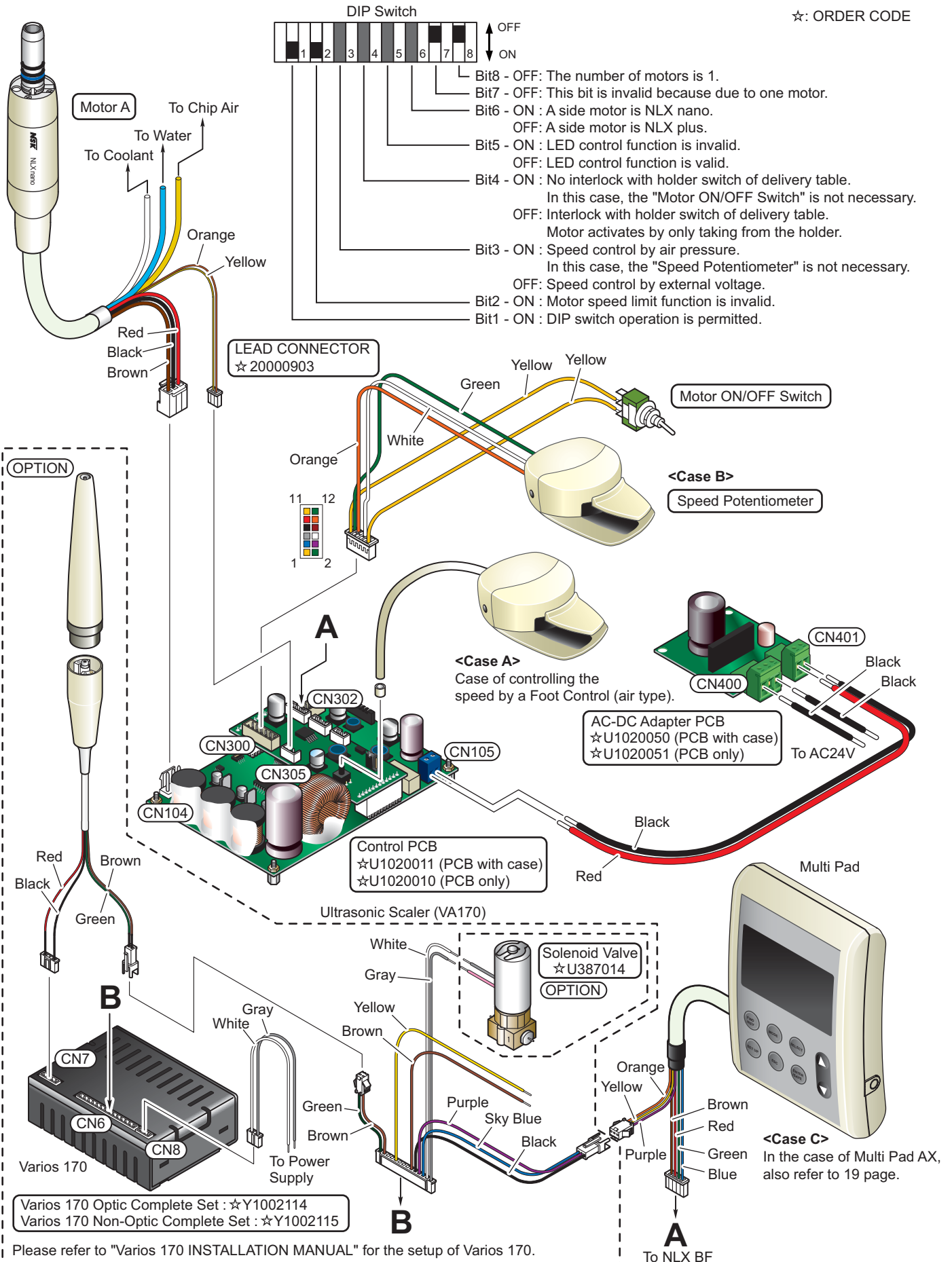

NLX BF Connections - One Motor Remote Control

Select how to control

- Case A : CAN
 Multiple connection is available.
- Case B : RS-232C
 Only connection 1:1.

☆: ORDER CODE

NLX BF PCB

IC301
 (Air Pressure Sensor)



CN300
 (External I/F)

1	MOT_ON	Yellow
2	MOT_ROT	Green
3	MOT_H/L	Blue
4	AUTO_R	Purple
5	AUTO_RF	Gray
6	SPEED_VR	White
7	LIMIT_VR	Black
8	TRQ_VR	Brown
9	MOT_MUX	Red
10	+5V	Orange
11	GND	Yellow
12	GND	Green

CN301 (CAN Bus)

1	CAN_L	
2	CAN_H	
3	Unused	

CN302 (RS-232C)

1	GND	
2	Unused	
3	RX_DATA	
4	TX_DATA	

CN305 (Lamp OUT)

1	LAMP_V	Orange
2	GND	Yellow

CN306
 (Motor Select OUT)

1	SEL_MA/B	Blue
2	+12V	Purple

CN104 (Motor OUT)

1	MOT_W	Brown
2	MOT_V	Black
3	MOT_U	Red

CN105 (DC IN)

1	GND	Black
2	DC+34V	Red

<Case A> CAN
 (☆20000906)



CAN for PC
 (CANUSB dongle)
 (☆20001441)



<Case B> RS-232C
 (☆20000902)



RS-232C for PC
 (serial port)
 (☆20001442)



AC-DC Adapter PCB

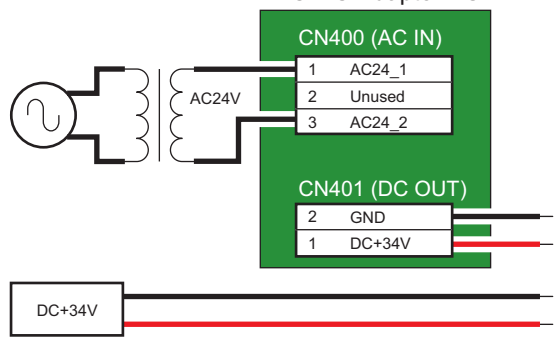

AC-DC Adapter is not necessary if DC power is supplied.



Wiring Diagram Case3 - One Motor Remote Control

☆: ORDER CODE

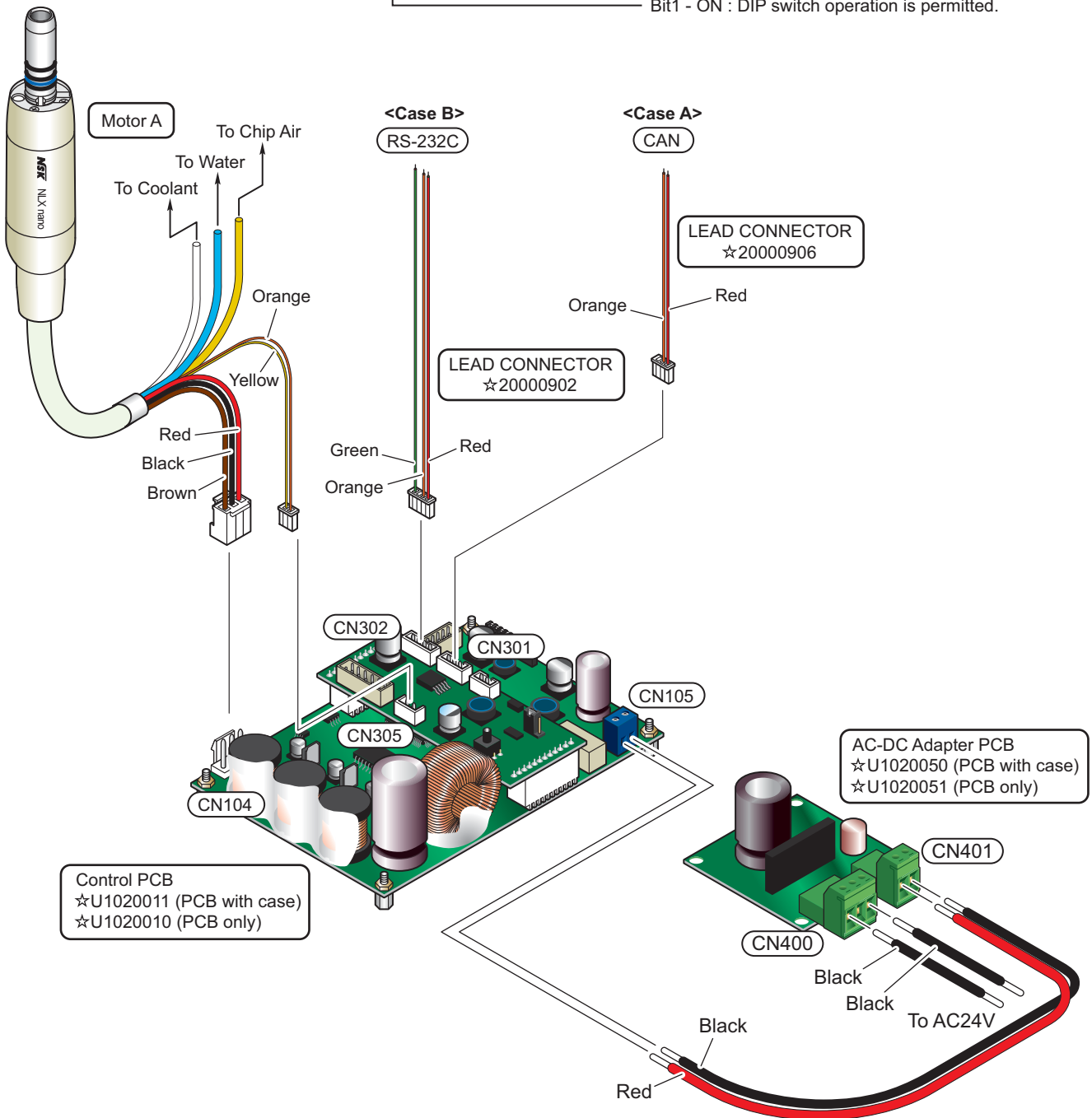
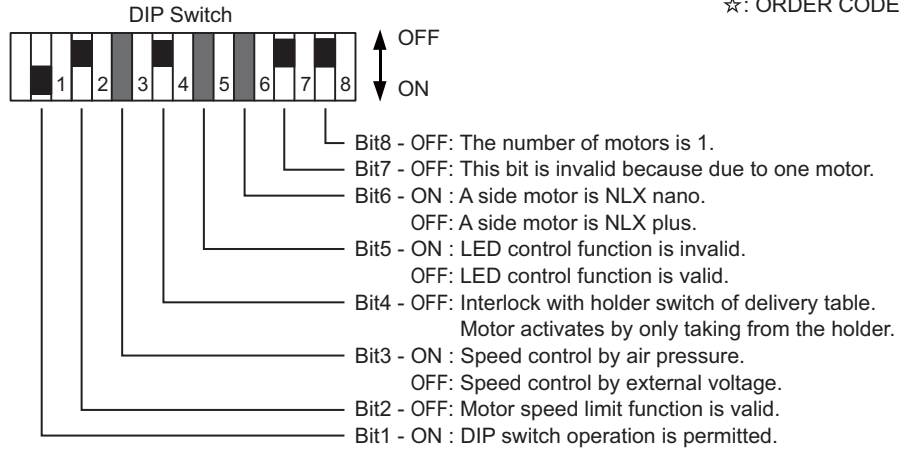

NLX BF Connections - Two Motors External I/F Control

Select how to control the speed

- Case A: By the air pressure control.
- Case B: By external voltage control.

<Case A> Speed controlled by air Foot Control

- Connect the air tube from drive air to IC301 (Air pressure sensor)
- DIP switch: Bit3 ON
- Drive air pressure : Max 0.29MPa
- For correlation of the motor speed and the air pressure, refer to 18 page.

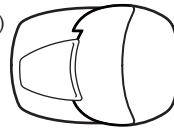

- Connect switch or transistor of open collector output with the switch.
- Connect potentiometer or DAC output from microcomputer with the potentiometer.

ON: Rotates by taking the motor from the holder
 OFF: No rotation
 DIP switch: Bit4 OFF

Motor ON/OFF Switch

Motor FWD/REV Switch

Motor High mode/Endo mode Switch

Not necessary for NLX nano motor.

Motor Auto Reverse ON/OFF Switch

Motor Auto Forward/ Auto Reverse Switch

<Case B>

Speed controlled by external voltage

- Connect wiring to the potentiometer.
- DIP switch: Bit3 OFF
- Speed Potentiometer
- For correlation of the motor speed and voltage of the potentiometer, refer to 18 page.

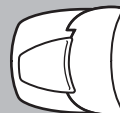

Not necessary if Bit2 of DIP switch is on.

Speed Limit Potentiometer

Not necessary for NLX nano motor.

Torque Potentiometer

Motor A/B Select Switch

AC-DC Adapter PCB

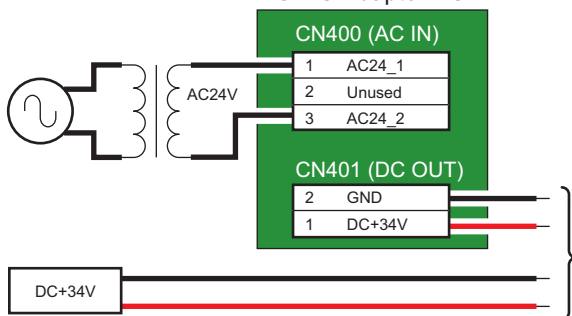

NLX BF PCB

IC301 (Air Pressure Sensor)

CN300 (External I/F)

1	MOT_ON	Yellow
2	MOT_ROT	Green
3	MOT_H/L	Blue
4	AUTO_R	Purple
5	AUTO_RF	Gray
6	SPEED_VR	White
7	LIMIT_VR	Black
8	TRQ_VR	Brown
9	MOT_MUX	Red
10	+5V	Orange
11	GND	Yellow
12	GND	Green

CN301 (CAN Bus)

1	CAN_L	Red
2	CAN_H	Orange
3	Unused	-

CN302 (RS-232C)

1	GND	Green
2	Unused	-
3	RX_DATA	Orange
4	TX_DATA	Red

CN305 (Lamp OUT)

1	LAMP_V	Orange
2	GND	Yellow

CN306 (Motor Select OUT)

1	SEL_MA/B	Blue
2	+12V	Purple

CN104 (Motor OUT)

1	MOT_W	Black
2	MOT_V	Brown
3	MOT_U	Red

CN105 (DC IN)

1	GND	Black
2	DC+34V	Red

Selector PCB

CN503 (Motor OUT_A)

1	MOT_WA	Brown
2	MOT_VA	Black
3	MOT_UA	Red

CN504 (Lamp OUT_A)

1	LAMP_VA	Orange
2	GND	Yellow

CN505 (Motor OUT_B)

1	MOT_WB	Blown
2	MOT_VB	Black
3	MOT_UB	Red

CN506 (Lamp OUT_B)

1	LAMP_VB	Orange
2	GND	Yellow

CN501 (Lamp IN)

1	LAMP_V	Orange
2	GND	Yellow

CN502 (Motor Select IN)

1	SEL_MA/B	Blue
2	GND	Purple

CN500 (Motor IN)

1	MOT_W	Black
2	MOT_V	Brown
3	MOT_U	Red

Motor A



Motor B



Wiring Diagram Case4 - Two Motors External I/F Control

☆: ORDER CODE

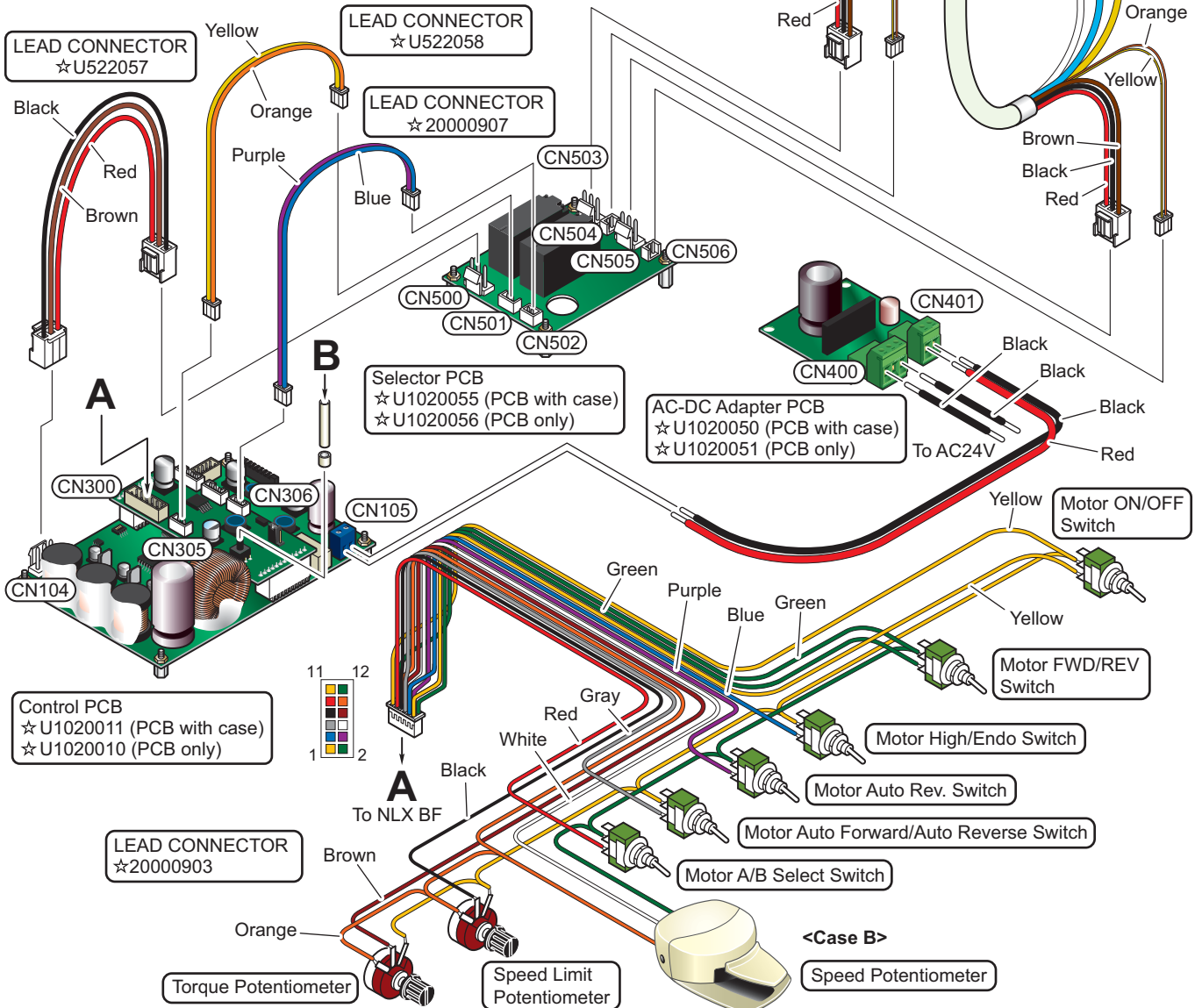
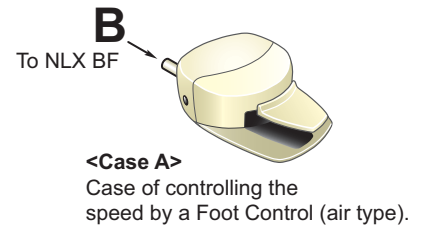
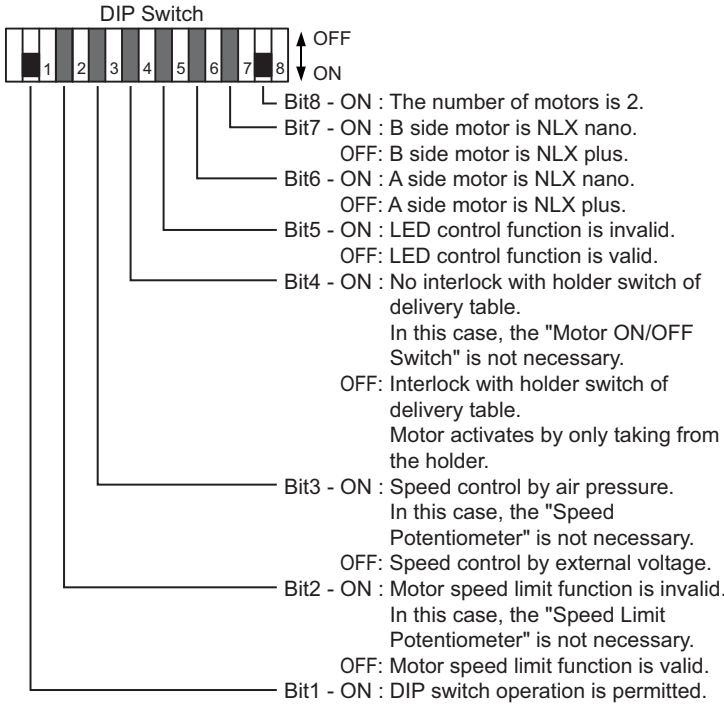

NLX BF Connections - Two Motors Multi Pad Control

Select how to control the speed

- Case A: By the air pressure control.
- Case B: By external voltage control.
- Case C: By Multi Pad control (MP02/MPS02 only). Refer to 19 Page.

<Case A> Speed controlled by air Foot Control

- Connect the air tube from drive air to IC301 (Air pressure sensor)
- DIP switch: Bit3 ON
- Drive air pressure: Max 0.29MPa

For correlation of the motor speed and the air pressure, refer to 18 page.

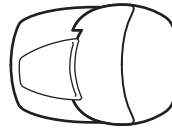

- Connect switch or transistor of open collector output with the switch.
- Connect potentiometer or DAC output from microcomputer with the potentiometer.

ON: Rotates by taking the motor from the holder
 OFF: No rotation
 DIP switch: Bit4 OFF

Motor ON/OFF Switch

Speed Potentiometer

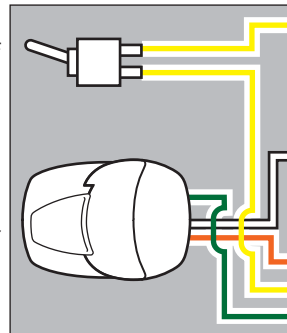

<Case B>

Speed controlled by external voltage

- Connect wiring to the potentiometer.
- DIP switch: Bit3 OFF

For correlation of the motor speed and voltage of the potentiometer, refer to 18 page.

NLX BF PCB

IC301 (Air Pressure Sensor)

CN300 (External I/F)

1	MOT_ON	Yellow
2	MOT_ROT	Green
3	MOT_H/L	Blue
4	AUTO_R	Purple
5	AUTO_RF	Gray
6	SPEED_VR	White
7	LIMIT_VR	Black
8	TRQ_VR	Brown
9	MOT_MUX	Red
10	+5V	Orange
11	GND	Yellow
12	GND	Green

CN301(CAN Bus)

1	CAN_L	Red
2	CAN_H	Orange
3	Unused	-

CN302(RS-232C)

1	GND	Blue
2	+12V	Green
3	RX_DATA	Red
4	TX_DATA	Brown

CN305(Lamp OUT)

1	LAMP_V	Orange
2	GND	Yellow

CN306 (Motor Select OUT)

1	SEL_MA/B	Blue
2	+12V	Purple

CN104 (Motor OUT)

1	MOT_W	Black
2	MOT_V	Brown
3	MOT_U	Red

CN105 (DC IN)

1	GND	Black
2	DC+34V	Red

Selector PCB

CN503 (Motor OUT_A)

1	MOT_WA	Brown
2	MOT_VA	Black
3	MOT_UA	Red

CN504 (Lamp OUT_A)

1	LAMP_VA	Orange
2	GND	Yellow

CN505 (Motor OUT_B)

1	MOT_WB	Brown
2	MOT_VB	Black
3	MOT_UB	Red

CN506 (Lamp OUT_B)

1	LAMP_VB	Orange
2	GND	Yellow

CN501 (Lamp IN)

1	LAMP_V	Orange
2	GND	Yellow

CN502 (Motor Select IN)

1	SEL_MA/B	Blue
2	GND	Purple

CN500 (Motor IN)

1	MOT_W	Black
2	MOT_V	Brown
3	MOT_U	Red

Motor A

Motor B

Ultrasonic Scaler (VA170)

OPTION

OPTION

To Power Supply
AC24V±10%
or DC24-36V

Varios 170

CN8 (Power Supply)

1	AC1	Gray
2	AC2	White

CN6 (Signal Part)

1	VRECTIFIED	Gray
2	VALVE_OUT	White
3	TOUT	Sky Blue
4	RIN	Purple
5	GND	Black
6	FC	Brown
7	RANGE 0	Pink
8	RANGE 2	Red
9	RANGE 1	Orange
10	VOL_GND	Yellow
11	ANA	Green
12	VOL_Vcc	Blue
13	LED1	Brown
14	LED2	Green

CN7 (Output)

1	TRD0	Black
2	TRD1	Red

Solenoid Valve

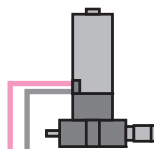

Foot Control*

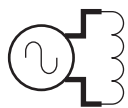

AC-DC Adapter PCB

CN400 (AC IN)

1	AC24_1
2	Unused
3	AC24_2

CN401 (DC OUT)

2	GND
1	DC+34V

AC-DC Adapter is not necessary if DC power is supplied.

* Not necessary when using Multi Pad control (MP02/MPS02).

Wiring Diagram Case5 - Two Motors Multi Pad Control

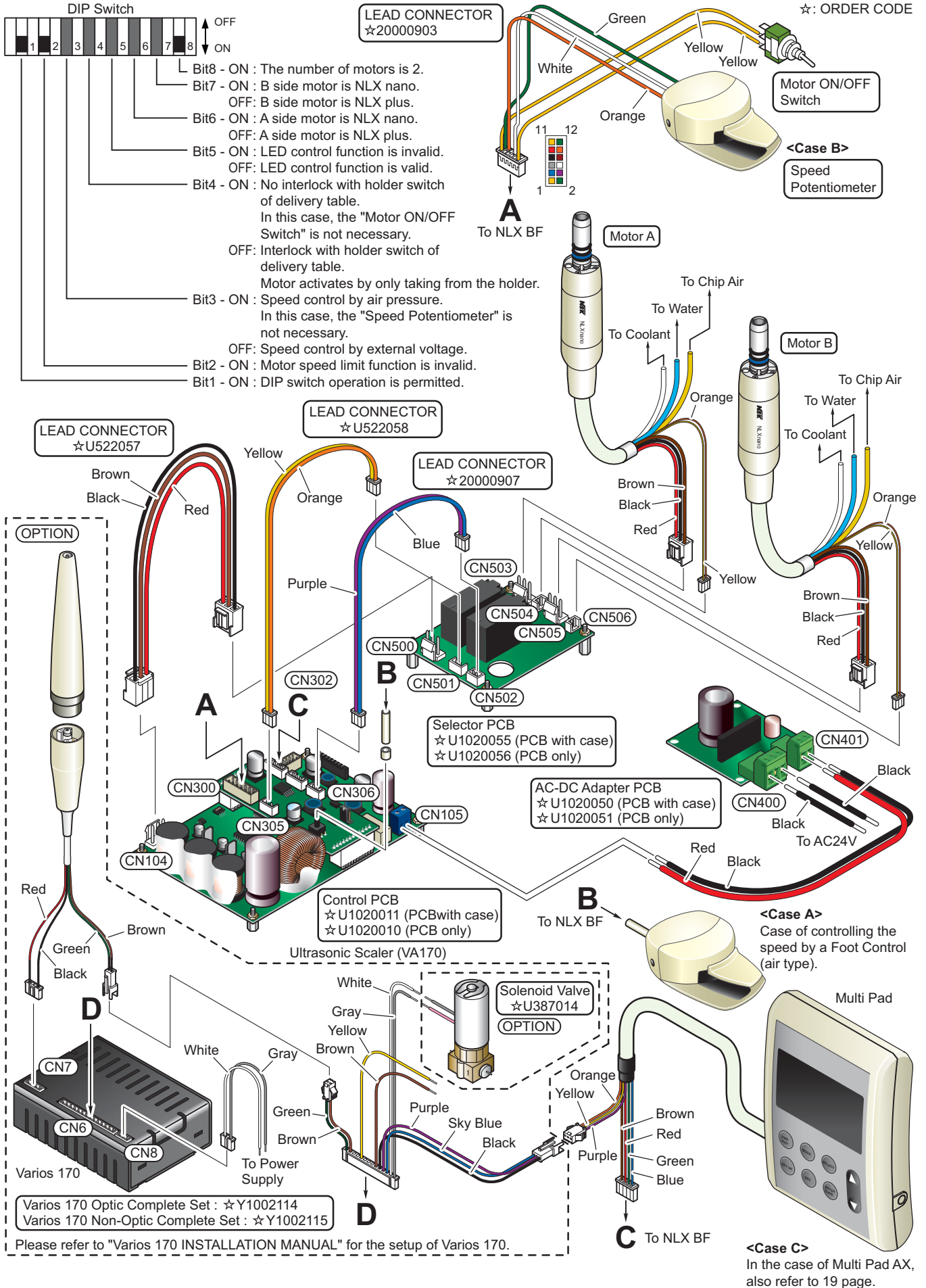

NLX BF Connections - Two Motors Remote Control

☆: ORDER CODE

Select how to control

- Case A : CAN
Multiple connection is available.
- Case B : RS-232C
Only connection 1:1.

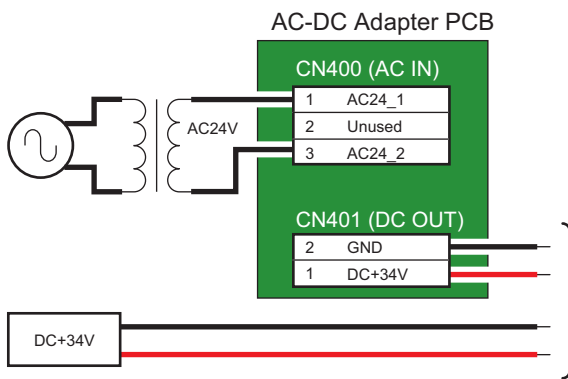
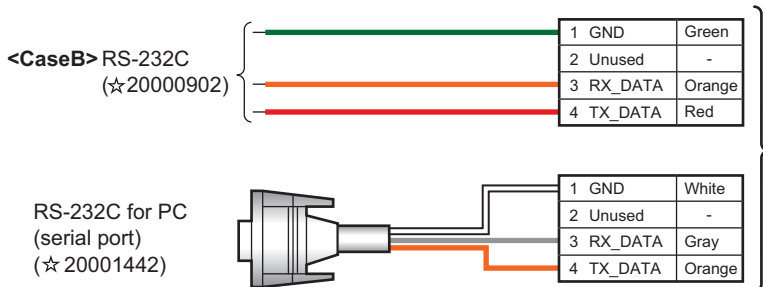
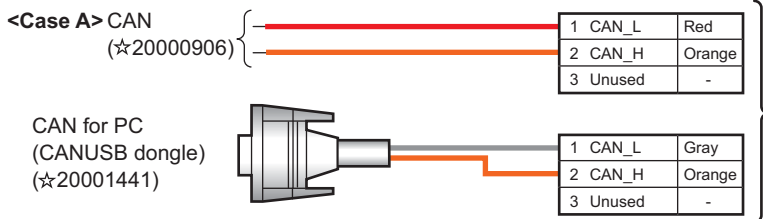

AC-DC Adapter is not necessary if DC power is supplied.

NLX BF PCB

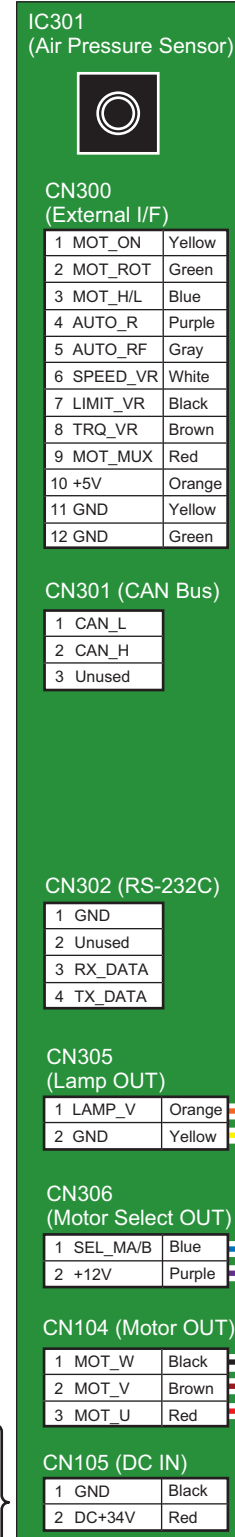

Selector PCB

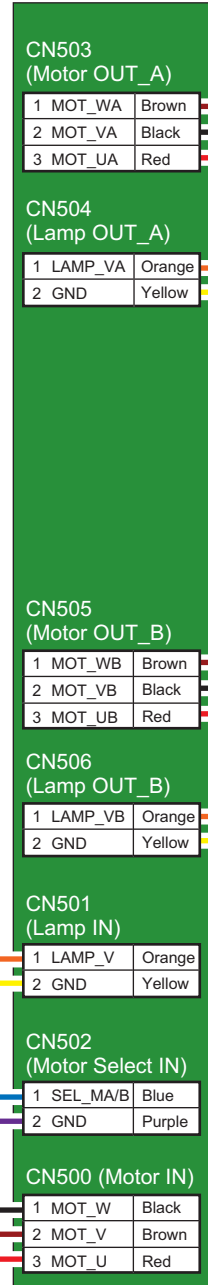

Motor A



Motor B



Wiring Diagram Case6 - Two Motors Remote Control

☆: ORDER CODE

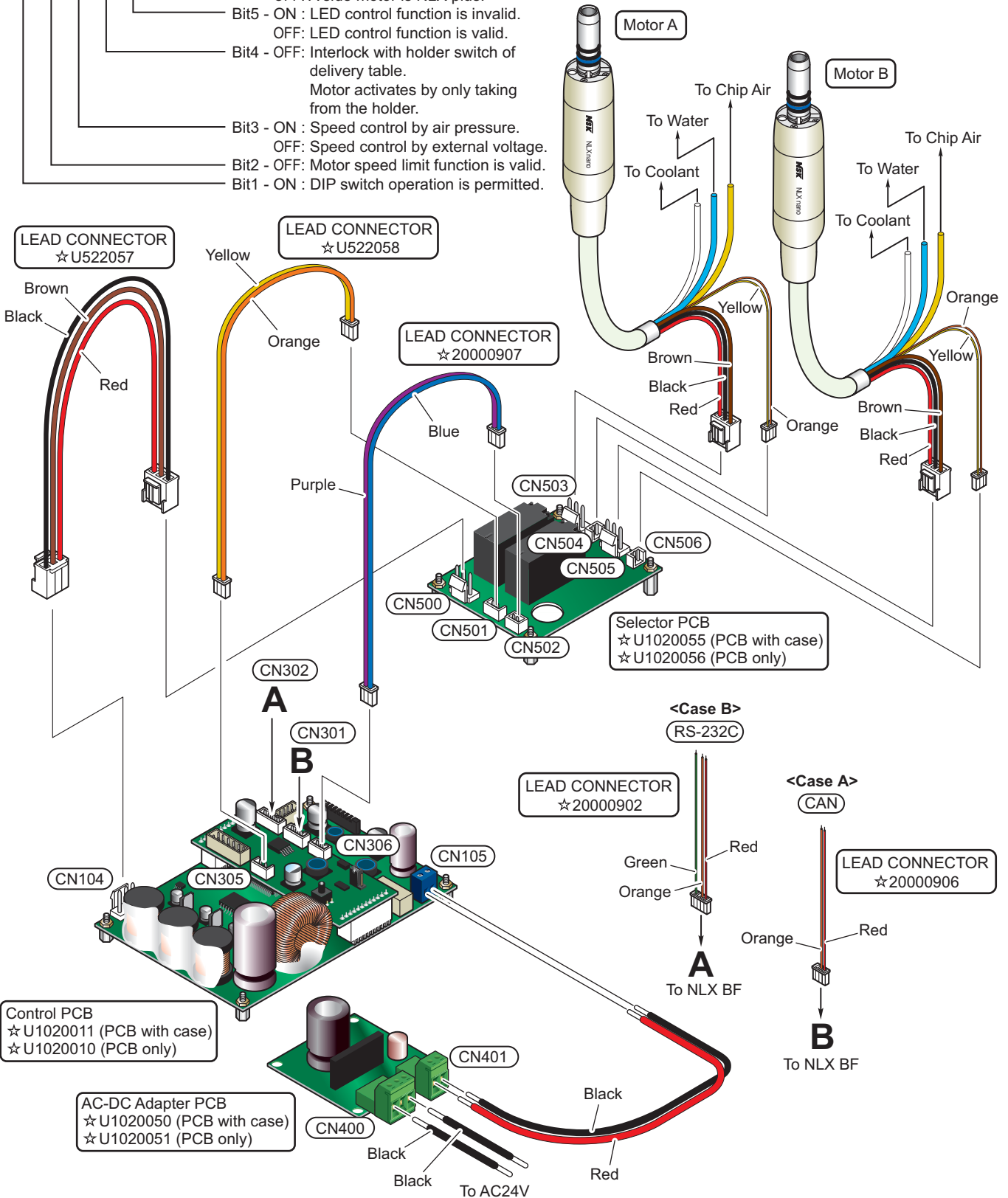
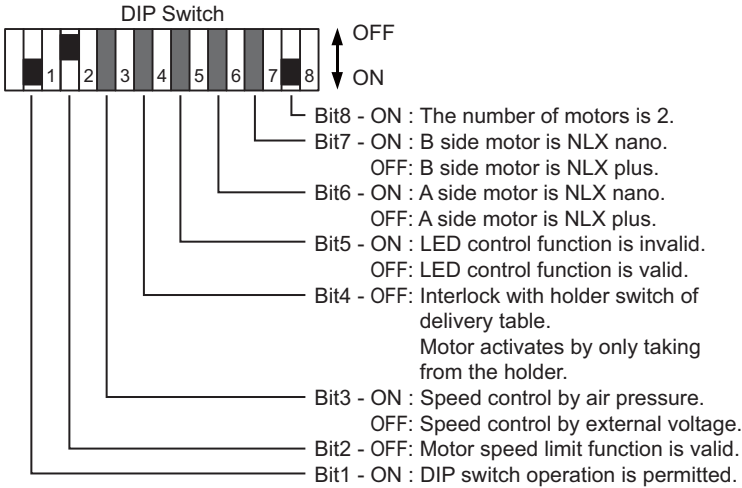

Correlation of the Motor Speed and the Air Foot Control Pressure

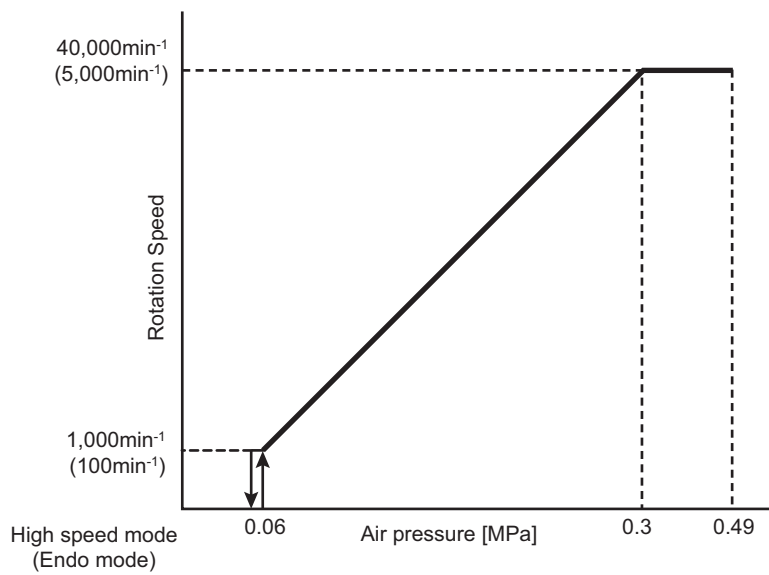

In the case of Multi Pad control, the air pressure of the motor start and maximum speed can be adjusted in the setting menu of Multi Pad.

Correlation of the Motor Speed and Voltage of the External I/F Speed Potentiometer

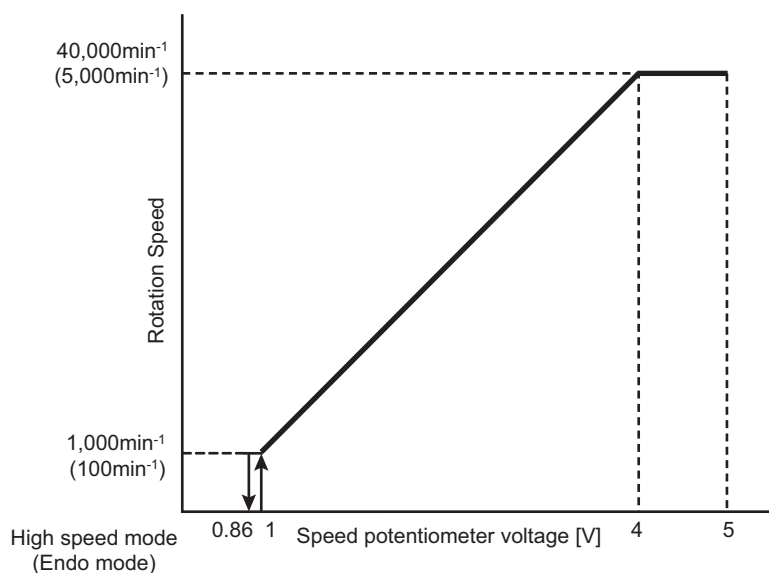

Wiring Diagram MP02/MPS02 (Multi Pad AX)

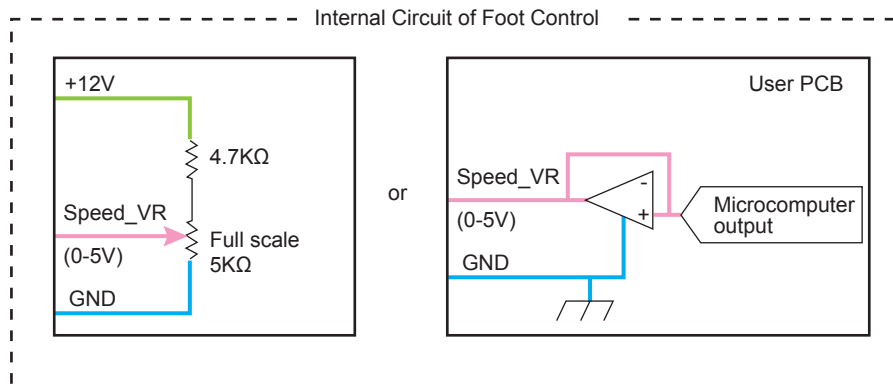
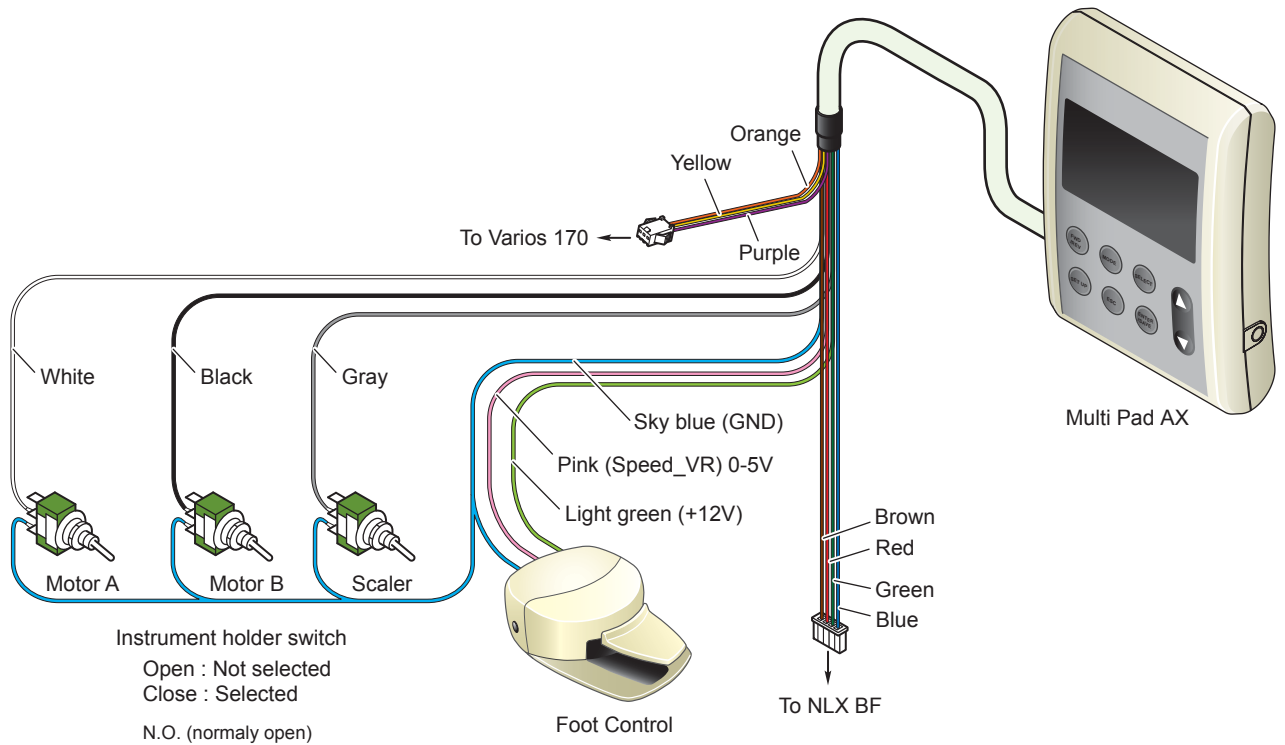

<In case that the system needs to be adjusted by air pressure>

No electric wiring for the Foot Control is needed. (Wiring for the switches are needed.)

Use the air tube and connect to the IC301 of NLX BF PCB. Also turn the Bit3 of the DIP switch ON position.

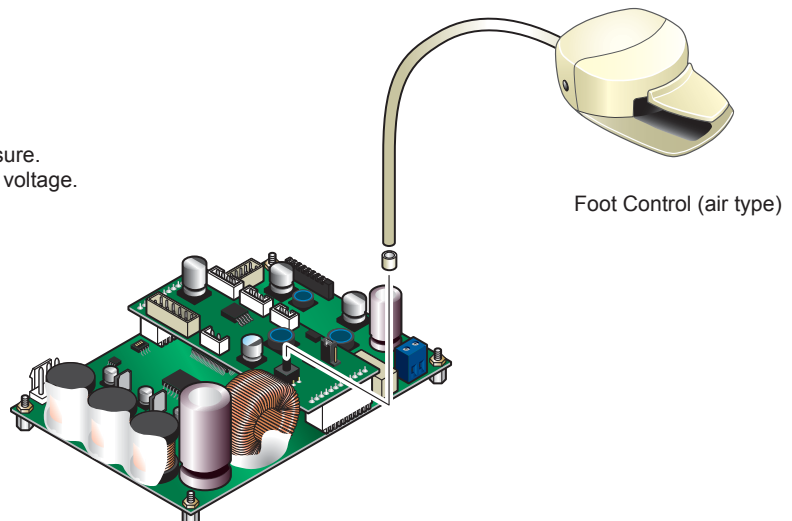
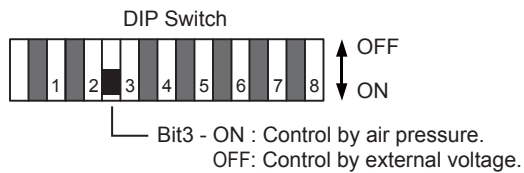

Insulate and bundle the wires which are not being used to avoid short-circuit.