

you can
WANHAO

Duplicator 7 Plus
PRODUCT BROCHURE



<https://stomshop.pro>

Technical Specifications

Primary attributes of the technology	DLP LCD printer, entrance level resin printer. Full assembled. With nanopie inside, print through Flash Disk only.
Extruder system	405 nm UV lamp, DLP curving system
With Insulate cover or not	Yes. Total Blinding hood
Max printable area	120.96*68.5*180mm
Software	Wanhao Slicer
Filament diameter/light	405nm UV light
Material support	405nm Resin
Max printing speed	30mm/hour
Case Material	Steel Case
Projection Size	5.5 inch LCD
Accuracy	X 0.00001mm Y0.00001mm Z 0.004mm
LCD display	NO
Net Weight(kg)	9.5kg
Gross Weight(kg)	10.5kg
Packing size(cm)	55x30x30cm
Layer Thickness	35-100 micron
Material cost	USD28-36/liter
Platform Holder	4 bolt adjusting system
Rail locking system	Steel bolt locking frame
Platform	Aluminum building plate
Price Range	Varied for different country
Power supply unit	Inside 110 AND 250V(Auto Switch), 50/60Hz, 4.0A (input), and takes standard IEC cable
Typical application	<ul style="list-style-type: none">•A perfect printer for educators who intend to use the printers in technical education.•Great printer for DIY hobbist.

DUPLICATOR 7 PLUS



1. Red Anti Wobble cover
2. Aluminum Super Flat build plate
3. Vat Locking screw
4. Touching Screen
5. Double Rail Anti wobble system
6. Super flat, Re-usable Vat
7. Triple cooling fan

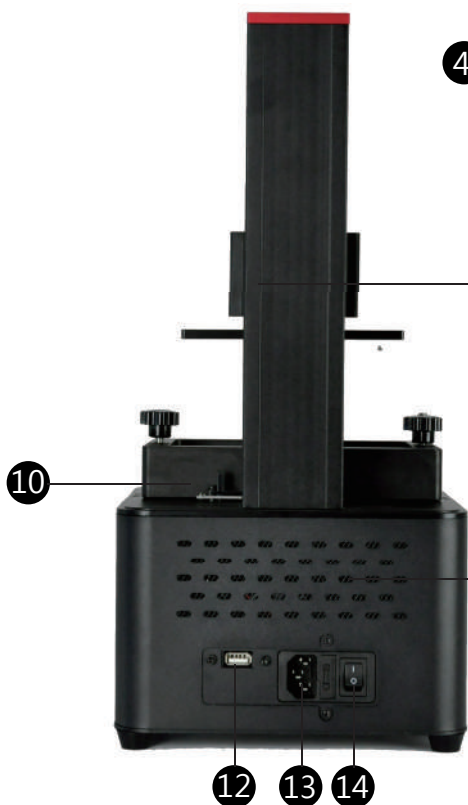
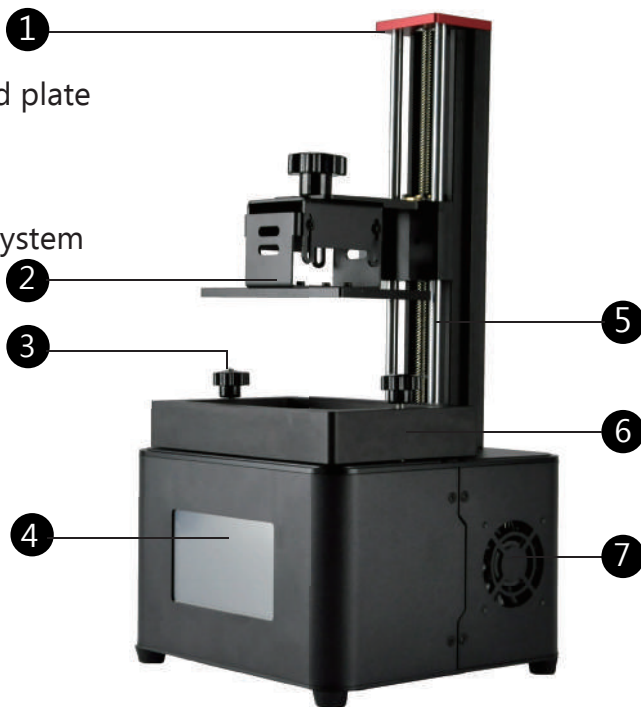

9. Aluminum stand beam
10. photoelectricity end stop switch
11. Vent hole
12. USB socket
13. Plug socket
14. Power switch

3 STEPS TO SMART PRINTING

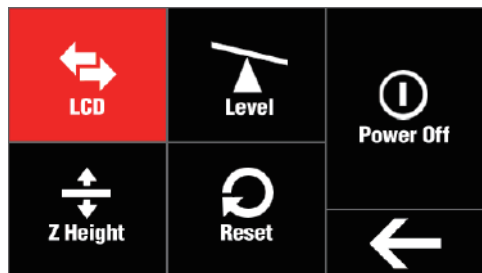

STEP1. CLICK LCD TO ENSURE CORRECT PROJECTION



STEP3. HOME Z AXIS

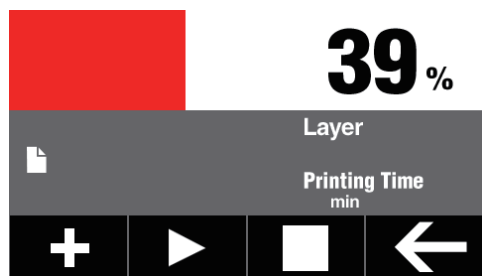

VISUAL PRINTING PERCENTAGE

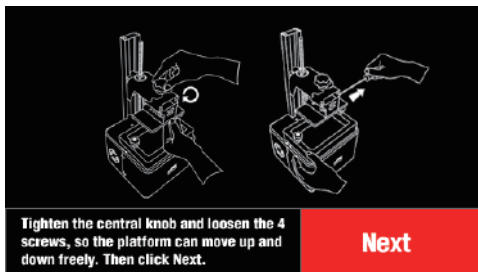

STEP2. CLICK LEVEL AND FOLLOW IMAGE INSTRUCTION TO LEVEL THE PRINTING PLATFORM

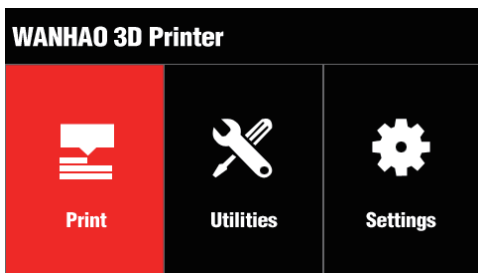

START PRINTING

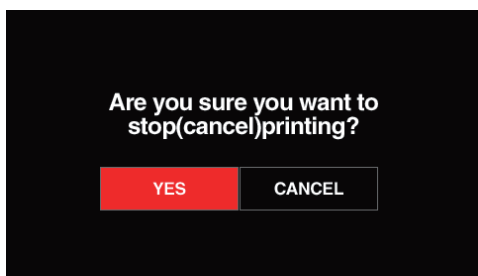

ADDITION PRINTING CHOICE, ENABLE YOU TO CANCEL PRINTING

DUPLICATOR 7 PLUS

High Precision 3D printer for Jewelry, dental and hobbyist.

WANHAO offers solutions to the challenges facing today's jewelry, Dental manufacturers and hobbyist. Our affordable 3D Printing technology enable access for more students and hobbyist, improves product quality and reduces time-to-market. Integrating our highest resolution DLP LCD 3D Printers with our WANHAO Jewelry resin specialty material provides two options to a final product: direct casting of the pattern in the case of complex geometries or replace manually created silver masters for HTV and/or RTV molding.



PRECISION AND ACCURACY

Stunning symmetry, exacting wall thickness and extreme detail.



DIRECTLY CASTABLE

100% castability in gold, silver, platinum and all castable materials.



ACCESS TO THE HIGH QUALITY OF PRINT

Jewelry and dental work preferred.



SUPERIOR SURFACE FINISH

Pristine, smooth wax models require virtually no finishing.



EASY TEAR OFF SUPPORTS

Auto-generated support easy to be tear off and sand to smooth.



MULTIPLY RESIN CHOICE

Fast melt out, no thermal expansion and no ash or residue.



INTUITIVE 3D PRINTER SOFTWARE

Machine compatible to multiple software with different advantage.



INCREASED PROFITABILITY

Create custom parts at mass production costs.



DESIGN FREEDOM

Innovate without limits, eclipse the competition.

<https://stomshop.pro>

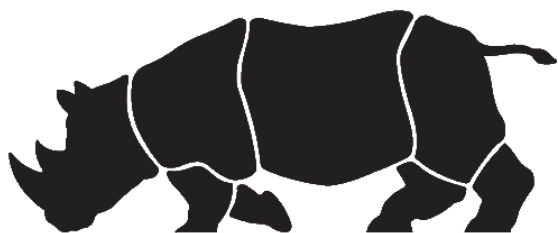

WANHAO