

Fine Blasting Unit Cemat II



Cemat-2 II



Cemat-3 II



Cemat-4 II



USER MANUAL

Dear customer,

Thank you for choosing a product from the Wassermann range. Wassermann Dental-Maschinen incorporates the highest standards of quality and the latest technology. In order to enjoy maximum performance and years of trouble-free operation, please read this user manual carefully before you connect this device and start work, and operate the device according to the recommended guidelines. The operation safety and the functionality of this device can only be guaranteed if you follow both the general safety guidelines and the applying laws to prevent accidents as well as the precautions given in this user manual. We are not liable for any damages which occur due to inappropriate usage or faulty operation of this device.



Make sure that anyone using this device has read and understood this user manual.

Keep this user manual in a safe place where it can be referred to as required at any time.



The unit complies with the relevant EU guidelines.



The unit is subject to the EU guidelines 2012/19/EU (WEEE Directive).

Company address:

Wassermann Dental-Maschinen GmbH

Rudorffweg 15-17

21031 Hamburg, Germany

Phone : +49 (0)40 730 926 -20/ -24 Fax.: +49 (0)40 730 37 24

export@wassermann-dental.com

www.wassermann.hamburg

www.facebook.com/WassermannDentalmaschinen

Contents

1 Features.....	4
2 Safety Symbols used in this Manual.....	6
3 Safety Guidelines.....	6
4 Responsibility for Operation or Damage.....	7
4.1 Warranty.....	7
5 Application.....	7
6 Before Starting.....	8
6.1 Transport.....	8
6.2 Installation.....	8
6.3 Storage.....	8
7 Installation/ Start-up.....	9
8 Operation.....	10
8.1 General Operating Instructions.....	10
8.2 Sand-blasting, Roughening, Polishing.....	10
8.3 Blasting Material Setting.....	10
8.3.1 Sand Flow Rate Control: Adjustable Blasting Material Consumption.....	11
9 Troubleshooting.....	12
10 Care and Maintenance.....	13
10.1 Cleaning.....	13
10.1.1 Operation of the Cleaning Nozzle.....	13
10.2 Maintenance/ Replacing worn Components.....	14
10.2.1 Sleeve Replacement.....	14
10.2.2 Screen Replacement.....	14
10.2.3 LED Replacement.....	15
10.2.4 Conducting Hose Replacement.....	16
10.2.5 Nozzle Replacemant.....	17
10.2.6 Overview of Nozzles and Blasting Material.....	17
10.2.7 Protection Filter Replacement.....	18
10.2.8 Water Separator.....	18
10.3 Scope of Delivery/ Accessories/ Spare Parts.....	19
10.3.1 Spare Parts.....	20
10.3.2 Service Hotline 0049 (0)40 730 926 -20/ -24.....	20
10.4 Repairs.....	20
11 Technical Data.....	20
12 Disposing of the Unit.....	21
12.1 Information on Disposal for Countries within the EU.....	21
13 EU Declaration of Conformity.....	22

1 Features

This precision fine blasting unit of the Wassermann-brand offers you the highest quality and most advanced technology.

This 2 to 4-chamber-unit is perfect for sand-blasting, roughening and polishing. The unit works precisely and requires little maintenance. The entire system is continuously under pressure and is therefore always ready for use. The relation between air and the blasting material is set at the factory. It is determined by the size of the drillings. The pressure reducer at the rear of the unit is set at the factory to 6 bar. This setting **must not be changed**. Adjustment of the abrasive pressure is done only using the black knobs at the front top of the unit. This set discharge velocity determines the outflowing amount of blasting media (while the relation is kept optimal and constant). In addition to this pressure setting the sand flow rate can be adjusted with a regulator per tank (see page 11). This unit is equipped with a plug socket (power consumption: max 8 A).

- Extra efficient, comfortable and flexible:
Multifunctional fine blasting units with either 2, 3 or 4 full metal chambers
- Individually adjustable pressure control per chamber
- Precise working pressure of 0.8–6 bar with pressure gauge control
- With additionally flow rate control: Adjustable blasting material consumption
- Genuine quick start/stop function, cost savings thanks to noticeable low consumption of blasting material
- Permanent pressure system: Prevents contamination and moisture of blasting material
- Comfortably to handle with ergonomically shaped handpieces
- With handy air blasting nozzle for easy cleaning
- Easy foot-controlled operation
- Rapid ventilation of the high quality blasting material containers made of metal for rapid re-filling and changing of blasting material
- Sand drawer for catching coarse of materials to relieve filters
- Special particularly durable hoses
- High hygiene standard because of changeable sleeves
- Convenient colour coding system
- Easy choice of the desired blasting material by using the selection switch for colour circuit settings
- Specially coated safety screen for ideal visibility
- Optimum workspace illumination, protected LED lamp
- Blasting material tanks made of metal, high quality construction
- Designed for long durability
- Simple cleaning due to stay-clean surfaces: High quality stainless steel and robust plastic powder coating
- Air inlet membrane: If needed cut in the rubber vertically and horizontally to achieve an optimum exhaust air stream into the vent of the connected suction unit
- With plug socket (power consumption max. 8 A), e.g. for a suction unit
- Connection option for a suction unit: Extractor nozzle Ø 75 mm exterior
- Available as accessories: Extractor nozzle Ø 40 mm exterior (Item no. 143385)
Extractor nozzle Ø 50 mm exterior (Item no. 190286)

2 Safety Symbols used in this Manual



Warning!

This is a warning of risk situations and dangers.
Failure to observe this warning could be life-threatening.
These warnings has to be observed.



Information!

This symbol draws your attention to specific features that has to be observed.

3 Safety Guidelines

Configuring and operating this equipment requires ***precise knowledge*** and ***observance*** of the instructions in this ***user manual***. The equipment is designed only for its intended application.



WARNING:

Servicing and repairs should be carried out only by authorised specialists.
Disconnect the power plug before starting any maintenance work.



Make sure that the equipment is connected to the correct power source.



Because of a safety switch working is only possible while the blasting chamber is closed. Otherwise the safety switch cuts power to the system.



Please wear safety goggles!



WARNING:

Never connect to an oxygen bottle. Risk of dust explosion.

4 Responsibility for Operation or Damage

The responsibility for operating the device lies exclusively with the owner or user if said device is incorrectly serviced, maintained or altered by persons not employed by an authorised dealer or if the device is used in a manner contrary to its specified purpose. The unit has to be maintained and operated in accordance with this user manual. Wassermann Dental-Maschinen GmbH is not responsible for damage arising from the **nonobservance** of these instructions.

Warranty and responsibility provisions contained in the sales and supply conditions of Wassermann Dental-Maschinen GmbH are not extended by these instructions.

4.1 Warranty



The warranty period for our equipment is 12 months. If faults occur within the warranty period, contact your dental depot or get in touch directly with our service department.

Your equipment should only be operated in perfect condition. If faults occur which could harm operators or third parties, the unit should not be used until it has been fixed.

This warranty does not cover damage caused by improper use, external mechanical causes, transport damage or interference with the unit by unauthorized persons.

5 Application

Fine blasting units with 2 to 4 chambers. They are used for sand-blasting, roughening and polishing, and to bring a lasting finish to the workpiece.

Only use the device for this type of application.

6 Before Starting

6.1 Transport

Before transporting the unit, ensure that it has been unplugged from the power socket. Make sure that it is packed correctly in order to avoid accidental damage.



Be sure to check for any transport damage when unpacking the goods. Note down any damage if found.

6.2 Installation

- Open the box, remove the packing materials, and carefully lift out the device and accessories.
- Avoid lifting the unit on the mounting bracket of the air control unit because it could bend or break.
- The unit has to stand horizontally on a steady and even surface.
- Check the included accessories.



Install the device in a place where it will not block the working area and the functionality (take the dimensions into account).



Do not install the unit outdoors or in places without proper ventilation.

Before start-up, be sure the device reaches room temperature.

6.3 Storage

The unit location is very important when it comes to workplace safety, even if it is only to be set up there for a short period. The room should be dry, well ventilated and vibration-free. An even temperature and wooden supports also help. The unit should not be stored or set up outdoors. If the unit is to be stored for an extended period, protect it from moisture and dust.

7 Installation/ Start-up



Before starting the unit, connect up the following:

- Connect the unit to the compressed-air line.
- The fine blasting unit also has to be connected to an external suction unit.
- The nozzle for a suction unit is at the lower rear.
- **Finally**, insert the power plug into the socket, making sure that the mains and the unit operate on the same voltage (100-240 V / 50/60 Hz).



Power consumption of the interated plug socket: max. 8 A



Before using the unit, let it stand with open chambers until it has reached room temperature.



It is absolutely necessary to switch the unit off before filling.

- The red chamber should be filled with 110-250 my material as standard.
- The blue chamber should be filled with 50-110 my material as standard.

Please pay attention to the maximum filling capacity of the chambers which is marked inside the chamber. The chambers are only allowed to be filled up to 2.5 cm from the upper chamber edge.



All chambers are vented by pressing the according air vent knob.

The chambers can be screwed on when they are completely pressureless. The chambers are vented by pressing the tank cover air vent knob. Switch off the unit and press these knobs of the screwed-on cover until no outflowing air can be heard.



Before setting on the containers you have to assure that the threads and sealing surfaces are free of blasting media grains.

- Screw on the screwed-on cover (hand-screwed). When all chambers have been screwed on the unit is ready for use and can be switched on.
- Insert the power plug firmly into the power outlet (100-240 V / 50/60 Hz).
- Switch on the main switch (green toggle switch).
- Set the pressure reducer to working pressure. There must be no hissing noise. Otherwise, please retighten the screwed-on cover by hand.

8 Operation

8.1 General Operating Instructions

All instructions for using the unit, whether in verbal or written form, are based on our own experience and experimentation and can only be regarded as guidelines.

8.2 Sand-blasting, Roughening, Polishing

- Switch on main switch (green toggle switch).
- Set the working pressure to the desired value (see 8.3 and 8.3.1).
- Determine the blasting chamber with the selector switch installed in the working space.
- Pick up the handpiece according to the selected color.
- Blasting process starts by using the foot switch.

8.3 Blasting Material Setting



The pressure reducer at the rear of the unit is set at the factory to 6 bar. This setting must **not** be changed. Adjustment of the abrasive pressure is done only using the black knobs at the front top of the unit.

- The pressure is adjusted by pulling the knob and turning to the **left (pressure decreases)** or to the **right (pressure increases)**.
- Then lock the knob by pressing it down.
- The set pressure can be read via the manometer. By varying the pressure, the outflow velocity is varied and thus also the amount of blasting material.
- Sand flow rate control see page 11

8.3.1 Sand Flow Rate Control: Adjustable Blasting Material Consumption

In addition to the pressure setting the sand flow rate can be adjusted with a regulator (per tank/ colour coding system, see figure):

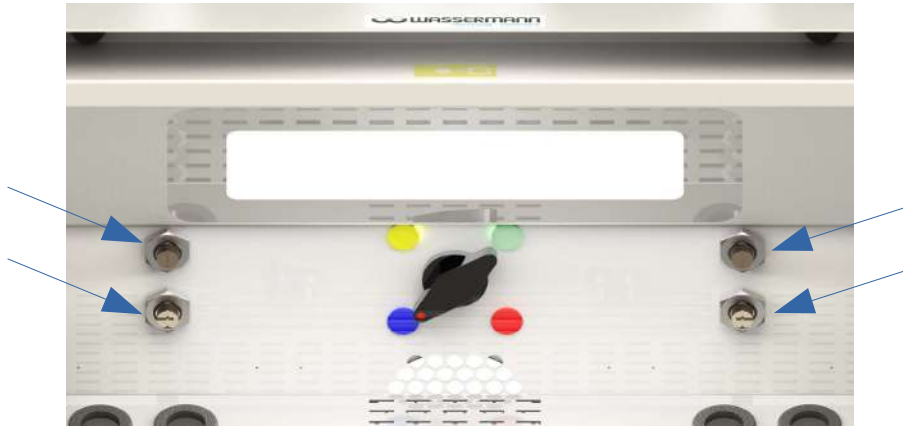

↻ to the left = more blasting material

↻ to the right = less blasting material



Due to the operating condition, the amount of blasting media flow may change when the blasting media amount decreases.

By slightly tilting the unit it is possible to continue working for a short time.

However, this is an indication that you have to refill blasting media.

9 Troubleshooting

Fault	Cause	Solution
irregular flow of blasting material	too little blasting material in container	re-fill the container
	nozzle on stylus too small	use larger nozzle
	blasting material is moist	use blasting material of correct dryness
no flow of blasting material	container empty	re-fill the container
	main nozzle and/or steel hose blocked	<ul style="list-style-type: none"> • use recommended, dry blasting material • unscrew nozzle on the stylus trigger blasting process blasting material should flow • if necessary, build up counterpressure by pressing the hose • clean the nozzle (make the stuck grains come loose) • if the obstruction persists, use compressed air or a needle to clean the nozzle
	wrong blasting container	please switch to the correct blasting container
	chamber nozzle blocked	Contact our Service: <ul style="list-style-type: none"> • item no. 190494 (Key for chamber nozzle) is necessary for dismounting • clean the nozzle (make the stuck grains come loose) • if the obstruction persists, use compressed air or a needle to clean the nozzle
	too little pressurised air < 3 bar	increase pressure
	flow rate at flow regulator set too low	increase flow rate with the flow rate control
decreasing and/or to low blasting pressure	protective filter (item no. 610039 Small Filter Plate D14 X 1.5) blocked and/or buckled closed	change filter plate item no. 610039 Small Filter Plate D14 X 1.5



If the above recommendations do not solve the problem, contact your dental depot or our service department.

Remarks: Obstructions normally occur from soiled or lumpy blasting material. If the sand draws moisture, check the condensator. Please also see page 18, 10.2.8 Water Separator.

10 Care and Maintenance

10.1 Cleaning



Disconnect the power plug before starting any maintenance work.

The identification plate has always to be kept in easily legible condition and has not to be removed.



Remove external dirt from time to time with some form of cold cleaner.

Use only cold cleaners to avoid damaging the paintwork or removing the lettering.

The equipment should be cleaned at regular intervals to ensure trouble-free operation.

It requires only normal cleaning (sponge, damp cloth, mild detergent) and no further chemical additives.

- Never use strong and abrasive solvents for cleaning the screens.
- The inside of the chambers and the protection screens can be cleaned with compressed air. Fine-dust will be sucked out by the dust-extractor.
- Coarse abrasive, which cannot be removed by the suction system, will fall through the grate and into the drawer. In this way, the suction filter is not overloaded and the chamber remains free of abrasive. The drawer has to be removed completely for emptying.

10.1.1 Operation of the Cleaning Nozzle

The instrument is fitted with a compressed-air nozzle for cleaning the inner area and the workpiece. You operate it by lightly bending the front section of the rubber pencil.

10.2 Maintenance/ Replacing worn Components



Always disconnect the power plug before starting any maintenance work.

This unit does not require any special maintenance. Just make sure that the device is kept clean.

However, after using the unit a certain time, it will be necessary to replace some parts. Please take care of the following parts:

10.2.1 Sleeve Replacement

Sleeves can also be replaced with gloves. The procedure is the same.

- Loosen the connector with pliers and unscrew the throughgrip (4 screws).
- Pull off the old sleeve and put on the new one so that it completely covers the opening.
- Attach the new connector. Take care that the closing of the connector is placed inside the notch of the opening.
- Tighten the opening.

10.2.2 Screen Replacement

- Open the flap and loosen the five knurled nuts.
- Remove the guide rail
- Fold the screen to the front and pull it out. Please take care of the spacer reels.
- Replace the specially coated safety screen and reassemble everything in reverse order.

10.2.3 LED Replacement

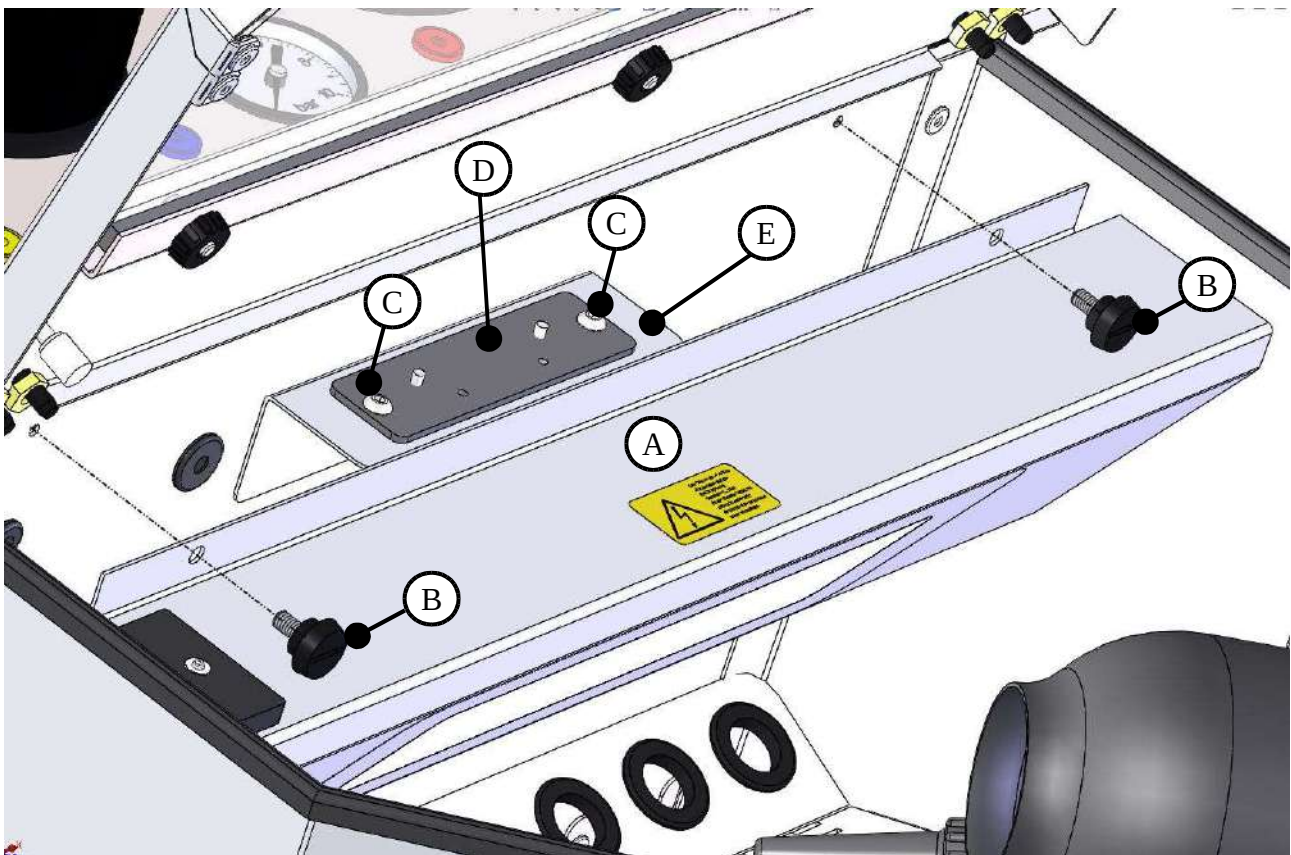

- For changing the LED lamp open the safety screen first.
- Than remove the lamp cover [A] by loosen the knurled screws [B].
- Resolve the plug connection of the LED power cable.
- Than remove the two screws [C] by using an Allen wrench.
- Remove the defective LED strip [D] from the retaining angle [E] and change it.
- Reassemble everything in reverse order.

10.2.4 Conducting Hose Replacement

Before changing, the mains plug must be disconnected and the pressurised air connection detached.

The pressure of all the tanks must be released (see page 9, Start-up).

- Take sieve unit out of the chamber.
- Lay the unit on its side so that you have access to the bottom of the unit.
- To detach the desired hose from the tank, solve the black hose clamp with a pliers, remove the hose from the chamber nipple
- Pull and/or lever the silver handle on the squeezing valve, with the other hand pulling the hose through the through-put and into the interior.
- Remove the slotted hose protection.

In principle the installation takes place exactly in the reverse manner:

- First, put the slotted protective hose over the blasting hose.
- Than insert the hose from the interior of the chamber through the hole in the rear.
- Than insert the hose through the squeezing valve.
- TIP: Slightly rotate the hose for easier passage of the fabric.
- TIP: Put the hose clamp already now around the hose.
- Than put the hose with the clamp on the nipple of the tank.
- The fabric must be completely pulled over the rubber. Should this be difficult to achieve then push the fabric outwards from the stylus right to the end until enough fabric is available.
- Put the hose clamp around the nipple of the tank and compress with the pliers.
- Put the unit back in an upright position and re-install the sieve grille. Please take care that the blasting hoses run along under the sieve grille.

10.2.5 Nozzle Replacemant

The replacement is very easy. Simply unscrew the old nozzle and screw on a new one.



Important!: Before setting up a new nozzle, shortly operate the unit and blow away old blasting material which may remain inside the hose.



Take care that the nozzle always corresponds to the size of the used blasting material (please see the following chart).

10.2.6 Overview of Nozzles and Blasting Material

Colour code* (tank/ handpiece):	yellow	blue	green	red
Fine blasting nozzle (handpiece)	0,6	0,8	0,8	1,2
Nozzle (tank) 1,4 (< 110 µm)	X	X		
Nozzle (tank) 2,0 (> 110 µm)			X	X
Aluminium Oxyde 50 µm	+++	++	+	-
Aluminium Oxyde 110 µm	+	+++	+++	+
Aluminium Oxyde 250 µm	-	-	+	+++
Glass Beads 50 µm	++	+	-	-
Glass Beads 110 µm	+	++	+++	+
Glass Beads 125 µm	-	+	++	+++

Annotation:

- X = Combination fine blasting nozzle (handpiece)/ nozzle (tank)
- = does not fit
- + = fits
- ++ = fits well
- +++ = optimal

The ratings in the table are standard values that may vary depending on the nature of the blasting material.

*This colour code with the above mentioned combination of the nozzles is delivered as standard (see page 19).

10.2.7 Protection Filter Replacement

After some time of usage the filter inlet may become clogged. This filter inlet is situated directly behind the filter block onto the blasting material container.

- Unscrew and remove the rear panel.
- Unscrew the screws of the filter block with the help of a 3-Allen key.
- Change the filter inlet inside the filter block (just press lightly) and screw it back onto the blasting material container.

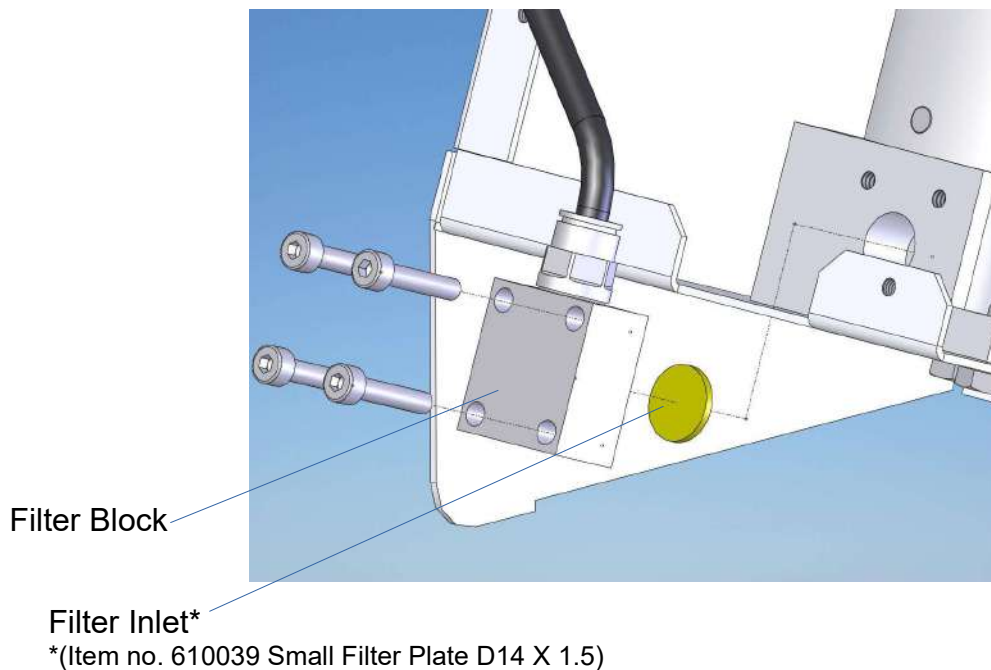

10.2.8 Water Separator

The pressure reducer at the rear of the unit comes with an integrated water separator, that absorbs any condensation coming out of the compressor. It must be checked regularly and at the latest when the max. level is reached, it must be emptied. To do this, pull the beige drain down so that the water can flow into the container you have placed under the unit.

10.3 Scope of Delivery/ Accessories/ Spare Parts

Included in Delivery	Item no.:
Cemat-4 II incl. 4 f.b.nozzles: 0.6 (yellow), 0.8 (blue), 1.2 (red), 0.8 (green)	190984
Cemat-3 II incl. 3 fine blasting nozzles: 0.8 (blue), 1.2 (red), 0.8 (green)	190983
Cemat-2 II incl. 2 fine blasting nozzles: 0.8 (blue), 1.2 (red)	190992
Compressed air hose, PVC-hose D 8x6 cloth (blue), 2 m	—
Delivered as standard: Supply line 3 core with angle plug	592012
Delivered only on request: Supply line 3 core US 13 A	592011

Accessories/ Spare Parts	Item no.:
Extractor nozzle Ø 40 mm exterior	143385
Extractor nozzle Ø 50 mm exterior	190286
Compressed air hose, PVC-hose D 8x6 cloth (blue), per meter	320026
Spare sleeve, per piece	190175
Spare hose -yellow-	190489
Spare hose -blue-	190485
Spare hose -red-	190475
Spare hose -green-	190487
Spare protection sheet with special coating	190432





We recommend the use of Wassermann blasting materials and our low-pressure suction units SG-10, SG-1/1 and SG-1/2 D with a long-life brushless motor and an extra large micro fine dust filterbag.

10.3.1 Spare Parts

If necessary please contact our service hotline phone.

10.3.2 Service Hotline 0049 (0)40 730 926 -20/ -24

10.4 Repairs



Servicing or repairs to the unit has only to be carried out by qualified technicians. Only original spare parts are to be used. Responsibility for the product is voided if unauthorised persons alter it or if inappropriate components are installed.

11 Technical Data

Cemat-4 II	Item no.: 190984
Cemat-3 II	Item no.: 190983
Cemat-2 II	Item no.: 190982
Voltage	100–240 V / 50/60 Hz
Power consumption	0.2 A
Plug socket power consumption max.	8 A
Output	50 W
W x H x D	445 x 460 x 620 mm
Weight Cemat-4 II/ -3 II/ -2 II	28 kg/ 26 kg/ 24 kg
Noise level	≤ 70 dB (A)
Tank capacity	560 cm ³
Compressed air connection	3-6 bar
Working pressure	0.8-6 bar
Extractor nozzle	75 mm exterior



Technical changes reserved.

12 Disposing of the Unit

The unit has to be disposed by an authorized recycling operation. The selected company has to be informed of all possibly health-hazardous residues in the unit.

12.1 Information on Disposal for Countries within the EU



To conserve and protect the environment, prevent environmental pollution and improve the recycling of raw materials, the European Commission adopted a directive that requires the manufacturer to accept the return of electrical and electronic units for proper disposal or recycling.

Within the European Union units with this symbol should not therefore be disposed of in unsorted domestic waste.

For more information regarding proper disposal please apply at your local authority.

13 EU Declaration of Conformity

in accordance with 2014/35/EU (Low Voltage Directive) and 2014/30/EU (Electromagnetic Compatibility Directive) and 2006/42/EC (Machinery Directive) and 2011/65/EU (RoHS Directive)

Manufacturer:	W A S S E R M A N N Dental-Maschinen GmbH Rudorffweg 15-17 21031 Hamburg Germany	Product description:	Fine Blasting Unit for dental applications
Model:	Cemat-4 II Cemat-3 II Cemat-2 II		Item no.190984 Item no.190983 Item no.190982
Applicable standards:	DIN EN 61010-1 DIN EN 61000-6-3 DIN EN 61000-6-1 DIN 45635-1 DIN EN 60335-1		

Hiermit wird bestätigt, dass die oben bezeichnete Maschine den genannten EU-Richtlinien entspricht. Diese Erklärung wird ungültig, falls die Maschine ohne unsere Zustimmung verändert wird.

This is to confirm that the above mentioned machine complies with the described EU rules. This declaration becomes invalid if the machine is modified without our approval.

Cette machine est conforme aux normes en vigueur d'Union européenne. Cet avis est nul et non avenant si cette machine est modifiée sans notre accord.

Esta máquina, anteriormente mencionada, cumple con los límites requeridos por el reglamento UE. Ahora bien, esta declaración quedará invalidada en caso de realizar modificaciones al aparato sin nuestra aprobación.

Hiermee wordt bevestigd dat bovengenoemde machine voldoet aan de voorgeschreven EU normen. Deze verklaring verliest geldigheid als er zonder onze uitdrukkelijke toestemming wijzigingen aan de machine worden aangebracht.

Place, date: Hamburg, 2020-02-28

Company stamp :



Signature: _____
Sven Wassermann
(Managing Director)



WASSERMANN
DENTAL-MASCHINEN GMBH
Rudorffweg 15-17 · 21031 Hamburg

Notes:



Wassermann Dental-Maschinen GmbH
Rudorffweg 15–17 · 21031 Hamburg · Germany
Phone: +49 (0)40 730 926-20/ -24 · Fax: +49 (0)40 730 37 24
export@wassermann-dental.com · www.wassermann.hamburg



/WassermannDentalmaschinen